



City Council Staff Report

DATE: September 2, 2015 CONSENT CALENDAR

SUBJECT: AWARD A CONSTRUCTION CONTRACT TO GOLDEN VALLEY CONSTRUCTION IN THE AMOUNT OF \$32,826 FOR THE FIRE STATION NO. 2, 911 MEMORIAL IMPROVEMENTS, CITY PROJECT NO 15-13

FROM: David H. Ready, City Manager

BY: Public Works & Engineering Department

SUMMARY

Award of this contract will allow the City to proceed with construction of the Fire Station No. 2, 911 Memorial Improvements, City Project No. 15-13.

RECOMMENDATION:

1. Award a construction contract (Agreement No. _____) to Golden Valley Construction in the amount of \$32,826 for the Base Bid Schedule only, for the Fire Station No. 2, 911 Memorial Improvements, City Project No. 15-13; and
2. Authorize the City Manager to execute all necessary documents.

STAFF ANALYSIS:

On March 30, 2015, Mayor Pougnet furnished a fundraising letter to local residents in support of construction of a 911 Memorial at Fire Station No. 2. An aerial map is identified below and a vicinity map is included in **Attachment 1**. The letter displayed multiple levels of sponsorship opportunities to local residents to help fund the construction costs of the 911 Memorial; the 911 Memorial will honor 343 firefighters, 60 police officers and thousands of innocent people who lost their lives on September 11, 2001.



Project Location

Subsequently, on April 14, 2015, the Mayor and Patty Delgado Service hosted a 911 Memorial Fundraiser at Las Casuelas Terraza. This event discussed future site improvements at Fire Station No. 2 as well as how the construction drawings were going to be funded. A copy of the fundraiser flyer is included in **Attachment 2**.

The City's Fire Department has retained a portion of a steel I-beam recovered from the Twin Towers site, which is currently located in the Fire Station No. 2 lobby. The intent of this 911 Memorial is to relocate the I-beam as a permanent public exhibit on the exterior of Fire Station No. 2. Joe Wertheimer, local sculptor, donated his design services for the exterior improvements and prepared illustrations such as steel tri-pod base to house the relocated steel I-Beam as the 911 Memorial, a design for a steel plasma cut silhouette with concrete base and extension and steel framing panels with angle iron and mountain tabs. A copy of the Mr. Wertheimer's artistic sketches is included as **Attachment 3**.

MSA Consulting, MRC Engineering, Inc., and Randy Purnel Landscape Architects all donated their design services and prepared construction drawings for the on-site improvements which consists of constructing a new concrete sidewalk path, colored concrete pavement, concrete steps and hand railing, adjustable recessed lighting, exterior accent lighting, flood lights, lighting fixtures on flag pole, LED lamps, planting and irrigation. Furthermore, by the request from Fire Chief Goetz, reconstruction of the driveway approach and driveway (including steel reinforcements) were included in this project to the extent sufficient funding was available. The construction drawings and cost estimate have been provided to staff.

Staff separated the work into three separate Bid Schedules, allowing for the total cost of the project to be separated between the construction of exterior improvements, installation of interior on-site improvements and the Fire Station driveway reconstruction; the scope of each Bid Schedule is provided here:

Base Bid Schedule (Exterior Improvements):

Generally, the Work comprises of exterior improvements including, but not limited to; installation of an aluminum commercial flag pole with foundation, installation of City furnished steel tri-pod base and relocate I-Beam Memorial complete and installation of a concrete bench. The Contractor shall perform minor clearing and grubbing, relocation of signs, relocation/adjustment of valves, removal and construction of a new concrete sidewalk path, colored concrete, concrete steps and hand railing, and any other appurtenant work.

Additive No. 1 Schedule (Landscaping/Lighting & Interior Improvements):

Generally, the Work comprises include, but not limited to; installation of City furnished steel plasma cut silhouette and install into and construct PCC foundation and base, installation of City furnished steel framing panels with angle iron and mountain tabs, relocation/installation of boulders, removal/relocation of trees, relocation/capping irrigation lines, repairing irrigation emitting devices, repairing bollard lights, flood lights, LED lamps, adjustable recessed lighting, exterior accent lighting, lighting fixtures on flag pole, electrical service connections, planting, irrigation, and any other appurtenant work.

Additive No. 2 Schedule (Fire Station Driveway Reconstruction):

Generally, the Work comprises include, but not limited to; reconstruction of asphalt concrete pavement, curb and gutter, driveway and driveway approach including steel reinforcements and any other appurtenant work.

Staff advertised and solicited the contract bid documents for the Fire Station No. 2, 911 Memorial Improvements, City Project No. 15-13. On August 20, 2015, the Procurement and Contracting Division received three (3) construction bids from the following contractors:

| Company | Location | Bid Amount |
|-------------------------------------|------------------|-------------------|
| Golden Valley Construction | Palm Springs, CA | \$104,575.50 |
| G & M Construction | Palm Springs, CA | \$155,049.00 |
| Atom Engineering Construction, Inc. | Hemet, CA | \$192,484.00 |

The basis of award was the lowest total bid, inclusive of the Base Bid and two Additive Bid Schedules. On that basis, Golden Valley Construction submitted the lowest responsive bid in the amount of \$104,575.50. A full bid summary is included as **Attachment 4**.

The lowest responsive bid from Golden Valley Construction includes the following costs for the three separate scopes of work:

| | |
|---|---------------------|
| Base Bid Schedule (Exterior Improvements): | \$32,826.00 |
| Add Bid Sch. 1 (Landscaping/Lighting & Interior Improvements): | \$29,235.00 |
| Add Bid Sch. 2 (Fire Station Driveway Reconstruction): | \$42,514.50 |
| Total Bid: | \$104,575.50 |

Since the intent was to fund this project through revenue raised from the recent fundraising efforts, the total funds collected through the multiple levels of sponsorships is \$34,800. Therefore, sufficient funding has been raised to award only the Base Bid Schedule (Exterior Improvements).

Public Works Contractor Registration Law (SB 854)

Under California Labor Code Section 1771.1, as amended by Senate Bill (SB) 854 (2014), unless registered with the State of California Department of Industrial Relations (DIR), a contractor may not bid, nor be listed as a subcontractor, for any bid proposal submitted for public works projects on or after March 1, 2015. Similarly, a public entity cannot award a public works contract to a non-registered contractor, effective April 1, 2015. Staff has reviewed the DIR's contractor registration database, and has confirmed that Golden Valley Construction is registered with the DIR, and is appropriately licensed.

Golden Valley Construction, of Palm Springs, submitted the lowest responsive bid. Staff reviewed the bid, references, and contractor's license, and found the Contractor to be properly licensed and qualified. A construction contract with Golden Valley Construction for the Project is included as **Attachment 5**.

Local Business Preference Compliance

Section 7.09.030 of the Palm Springs Municipal Code, "Local Business Preference Program," requires prime contractors to use good faith efforts to sub-contract the supply of materials and equipment to local business enterprises and to sub-contract services to businesses whose work force resides within the Coachella Valley. Golden Valley Construction is considered a local business, and demonstrated sufficient evidence of good faith efforts to sub-contract the supply of materials and equipment to local business enterprises.

ENVIRONMENTAL IMPACT:

Section 21084 of the California Public Resources Code requires Guidelines for Implementation of the California Environmental Quality Act ("CEQA"). The Guidelines are required to include a list of classes of projects which have been determined not to have a significant effect on the environment and which are exempt from the provisions of CEQA. In response to that mandate, the Secretary for Resources identified classes of projects that do not have a significant effect on the environment, and are declared to be categorically exempt from the requirement for the preparation of environmental

documents. In accordance with Section 15301 "Existing Facilities," Class 1 projects consist of operation, repair, maintenance, permitting, leasing, licensing, or minor alteration of existing public or private structures, such things as interior and exterior alterations involving interior partitions, plumbing, and electrical conveyances; therefore, the Fire Station No. 2, 911 Memorial Improvements, is considered categorically exempt from CEQA, and a Notice of Exemption has been prepared and will be filed with the Riverside County Clerk. A copy of the Notice of Exemption is included as **Attachment 6**.

FISCAL IMPACT:

This Project is being funded through donations received by local sponsors. At this time, \$34,800 of outside funding support has been received for the construction of the Fire Station No. 2, 911 Memorial Improvements.

Table 1 below illustrates the budget and incurred expenditures for the Project utilizing the Base Bid Schedule (Exterior Improvements). As shown in Table 1, the donations fundraised for the Project is \$34,800 and the remaining budget after completion of Base Bid work is identified.

Table 1

| Table of Project Costs | Amount |
|-----------------------------------|----------------|
| Donations (secured) | \$34,800 |
| Design Services (donated) | (\$0) |
| Project Administration | (\$0)* |
| Construction Inspection | (\$0)* |
| Construction Contract (Base bid) | (\$32,826) |
| Art Piece / Sculpture Fabrication | (\$275) |
| Budget Remaining | \$1,699 |

*City staff will provide oversight of project administration and inspection through the course of their normal duties.

Table 2 below illustrates the budget for the Project including Additive Bid Schedule 1 to include the exterior landscaping and lighting improvements, and interior artistic and sculpture elements within the Fire Station entrance. As shown in Table 2, an additional appropriation of \$38,261 would be required to fully fund the estimated cost of the Project.

Table 2

| Table of Project Costs | Amount |
|---|-------------------|
| Donations (secured) | \$34,800 |
| Design Services (donated) | (\$0) |
| Project Administration | (\$0)* |
| Construction Inspection | (\$0)* |
| Construction Contract (Base bid) | (\$32,826) |
| Construction Contract (Additive bid #1) | (\$29,235) |
| Art Piece / Sculpture Fabrication | (\$11,000) |
| Budget Deficit | (\$38,261) |

*City staff will provide oversight of project administration and inspection through the course of their normal duties.

Although the existing Fire Station #2 driveway would greatly be improved with a reconstruction, funding has not currently been budgeted for this capital improvement and would require an additional \$43,000 appropriation.

SUBMITTED:

Prepared by:

Approved by:

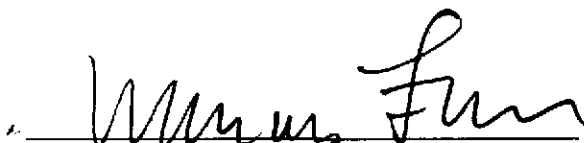

Marcus L. Fuller, MPA, P.E., P.L.S.
Assistant City Manager/City Engineer



David H. Ready, Esq., Ph.D.
City Manager

Attachments:

1. Vicinity Map
2. Support Letter
3. Sculpture Exhibits
4. Bid Summary
5. Construction Contract
6. CEQA Notice of Exemption

ATTACHMENT 1



Department of Public Works and Engineering
Vicinity Map

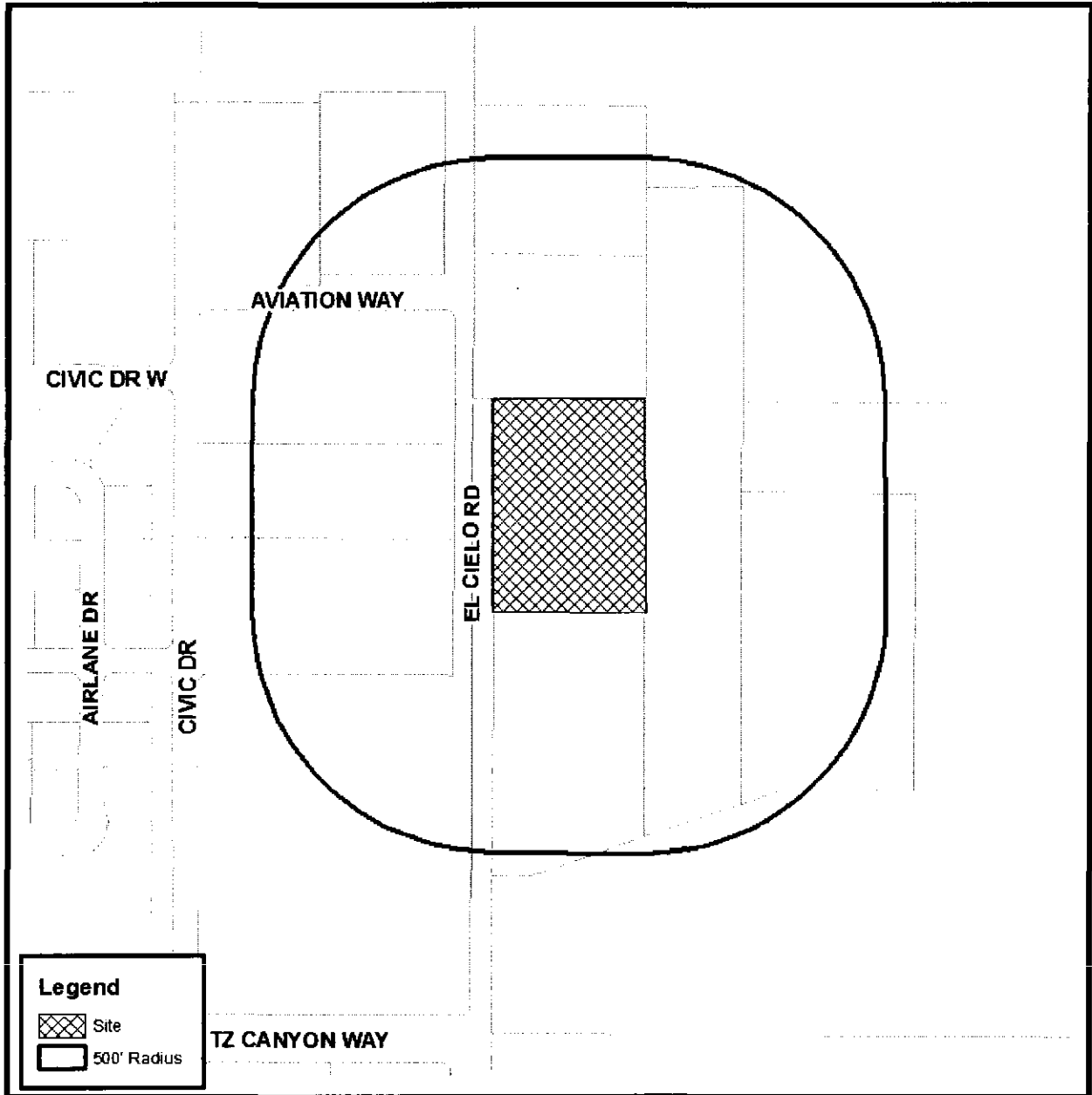
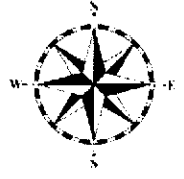

CITY OF PALM SPRINGS

ATTACHMENT 2

**LAS CASUELAS
TERRAZA**

**&
PALM SPRINGS FIREMENS**

**911 MEMORIAL
FUNDRAISER**

ASSOCIATION

**HOSTED BY
MAYOR STEVE POGNET
&
PATTY DELGADO SERVICE**

RSVP 760-323-8200

**TUESDAY APRIL 14TH
5:00 PM**

**222 S PALM CANYON DR.
PALM SPRINGS, CA 92262**

ATTACHMENT 3

— TIMELINE OF EVENTS 9.11 —

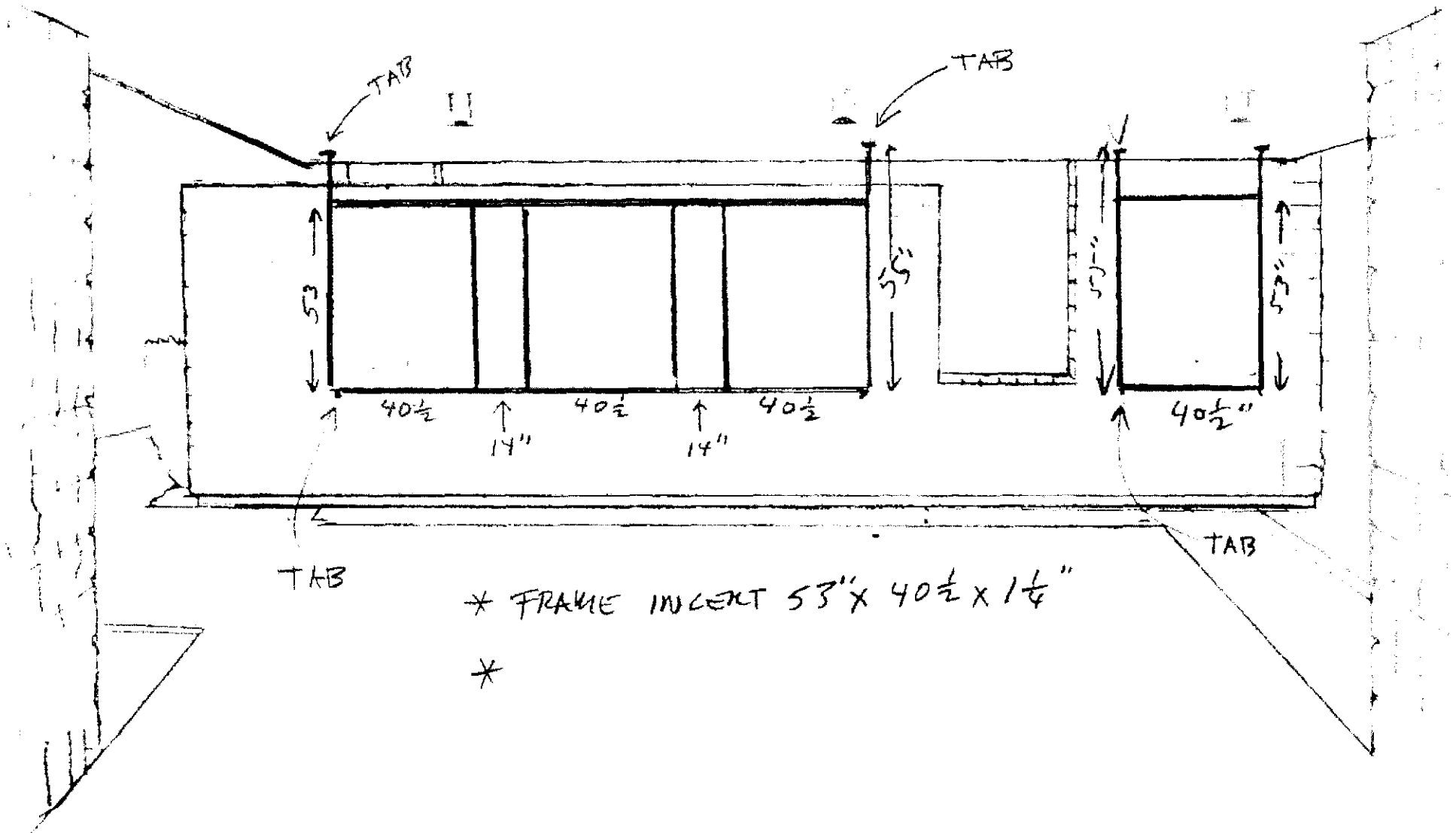

* FRAME INLET 53" x 40 1/2" x 1 1/4"

*

- TRIBUTE TO FALLEN FIREMEN -

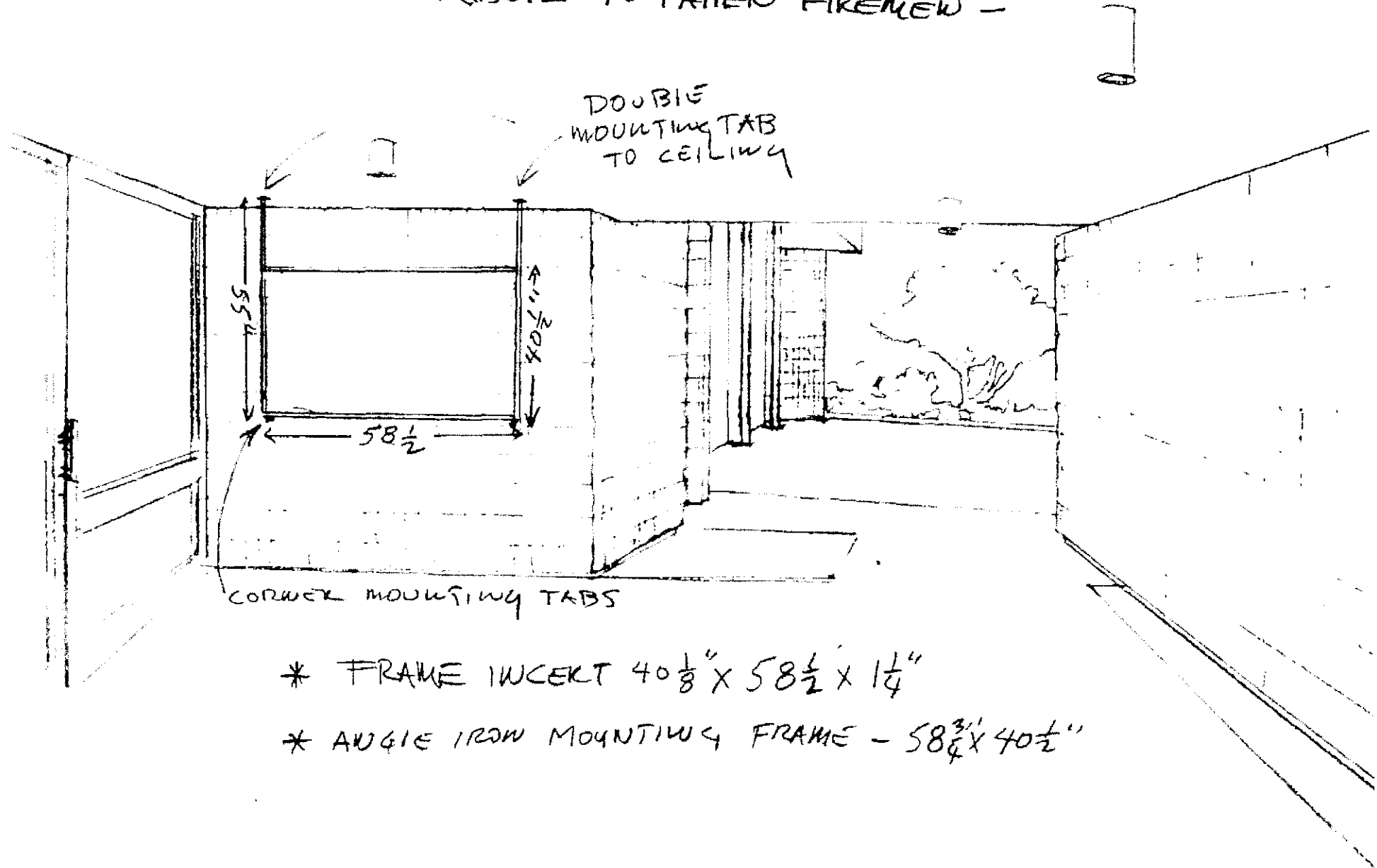

NOTE: NEED ONE

Wilton 6.7

12'

6'





GROUND
LEVEL

1
in

* 14" BASE WITH 2" HOLES TO RELIEVE CONCRETE
* 16" X 12" TROUGH TO PROVIDE CONCRETE BASE

11/18/51
61319

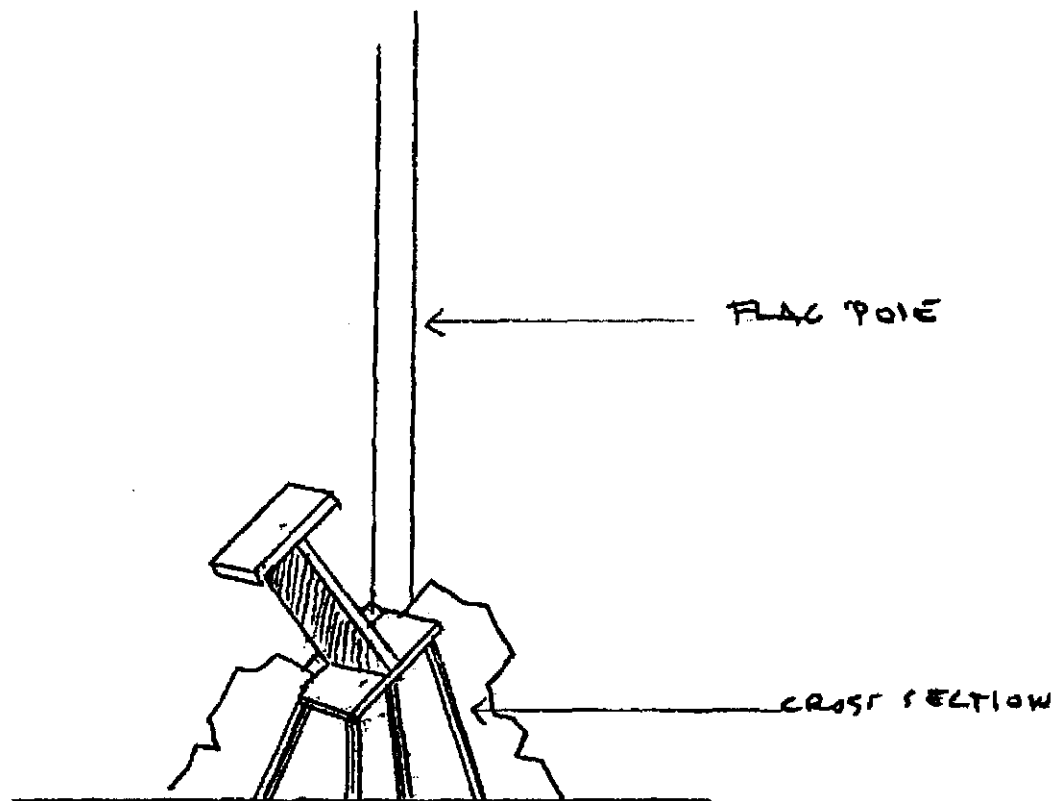

* $\frac{1}{2}$ " ANGLE IRON LEGS TO SET I BEAM

* AS CONCRETE RUBBLE IS BUILT PIECE BY
WILL BE CEMENTED IN PLACE AROUND BEAM
TO CREATE DESIRED HT.

W. Stra 7.1.15

ATTACHMENT 4

FIRE STATION NO. 2, 911 MEMORIAL IMPROVEMENTS, CITY PROJECT NO. 15-13

BID SUMMARY

Bid Opening: August 20, 2015

| BASE BID SCHEDULE | QUANT. | UNIT | GOLDEN VALLEY CONSTRUCTION | G & M CONSTRUCTION | ATOM ENGINEERING |
|---|--------|------|-------------------------------|-----------------------|---------------------|
| DESCRIPTION | | | | | |
| The Base Bid Work comprises of exterior and interior improvements including, but not limited to; <i>installation of an aluminum commercial flag pole with foundation, installation of City furnished steel tri-pod base for and relocate I-Beam Memorial complete, steel plasma cut silhouette with foundation and extension, and installation of a concrete bench, mirrored lint, custom framing and mounting, printing, and installation of a carved bas relief</i> at Fire Station No. 2 located at 300 N. El Cielo Road. The Contractor shall perform minor clearing and grubbing, relocation of signs, relocation/adjustment of valves, relocation of boulders , removal and construction of a new concrete sidewalk path, colored concrete, concrete steps and hand railing, adjustable recessed lighting, exterior accent lighting, lighting fixtures on flag pole, boulders, electrical service connections and any other appurtenant work as identified on Precise Grading Sheets the plans and the Special Provisions. | 1 | LS | \$32,826.00 | \$35,353.00 | \$67,398.00 |

| ADDITIVE BID SCHEDULE NO. 1 | QUANT. | UNIT | GOLDEN VALLEY CONSTRUCTION | G & M CONSTRUCTION | ATOM ENGINEERING |
|---|--------|------|-------------------------------|-----------------------|---------------------|
| DESCRIPTION | | | | | |
| The <i>Additive No. 1</i> Bid Work comprises for Fire Station No. 2 include, but not limited to; <i>installation of City furnished steel plasma cut silhouette and install into and construct PCC foundation and base, installation of City furnished steel framing panels with angle iron and mountain tabs, relocation/installation of boulders,</i> removal/relocation of trees, relocation/capping irrigation lines, repairing irrigation emitting devices, repairing bollard lights, flood lights, LED lamps, <i>adjustable recessed lighting, exterior accent lighting, lighting fixtures on flag pole, electrical service connections</i> , planting, irrigation, reconstruction of asphalt concrete pavement, curb and gutter, driveway and driveway approach including steel reinforcements and any other appurtenant work as identified on Sheets E1.0 and L0.0 thru L4.2 Complete the plans and the Special Provisions. | 1 | LS | \$29,235.00 | \$70,700.00 | \$71,100.00 |

| ADDITIVE BID SCHEDULE NO. 2 | QUANT. | UNIT | GOLDEN VALLEY CONSTRUCTION | G & M CONSTRUCTION | ATOM ENGINEERING |
|---|--------|------|-------------------------------|-----------------------|---------------------|
| DESCRIPTION | | | | | |
| The <i>Additive No. 2</i> Bid Work comprises for Fire Station No. 2 include, but not limited to; reconstruction of asphalt concrete pavement, curb and gutter, driveway and driveway approach including steel reinforcements and any other appurtenant work as identified on Precise Grading Sheet the plans and the Special Provisions. | 1 | LS | \$42,514.50 | \$48,996.00 | \$53,986.00 |

| | | | |
|---------|--------------|--------------|--------------|
| TOTAL = | \$104,575.50 | \$155,048.00 | \$192,484.00 |
|---------|--------------|--------------|--------------|

| | | |
|---|---|---|
| 1 | 2 | 3 |
|---|---|---|

ATTACHMENT 5

**AGREEMENT
(CONSTRUCTION CONTRACT)**

THIS AGREEMENT made this 2nd day of September, 2015, by and between the City of Palm Springs, a charter city, organized and existing in the County of Riverside, under and by virtue of the laws of the State of California, hereinafter designated as the City, and Golden Vista Construction, Inc., dba Golden Valley Construction, hereinafter designated as the Contractor.

The City and the Contractor, in consideration of the mutual covenants hereinafter set forth, agree as follows:

ARTICLE 1 -- THE WORK

For and in consideration of the payments and agreements to be made and performed by City, Contractor agrees to furnish all materials and perform all work required to complete the Work as specified in the Contract Documents, and as generally indicated under the Bid Schedule(s) for the Project entitled:

**FIRE STATION NO. 2
911 MEMORIAL IMPROVEMENTS
CITY PROJECT NO. 15-13**

The Work comprises of exterior improvements including, but not limited to; aluminum commercial flag pole with foundation, installation of steel tri-pod base for I-Beam, bench, at Fire Station No. 2 located at 300 N. El Cielo Road. The Contractor shall perform minor clearing and grubbing, relocation of signs, relocation/adjustment of valves, relocation of boulders, removal and construction of a new concrete sidewalk path, colored concrete, concrete steps and hand railing, and any other appurtenant work as identified as the "Base Bid Schedule" on the plans and the Special Provisions.

ARTICLE 2 -- COMMENCEMENT AND COMPLETION

The Work to be performed under this Contract shall commence on the date specified in the Notice to Proceed by the City, and the Work shall be fully completed within the time specified in the Notice to Proceed.

The City and the Contractor recognize that time is of the essence of this Agreement, and that the City will suffer financial loss if the Work is not completed within the time specified in Article 2, herein, plus any extensions thereof allowed in accordance with applicable provisions of the Standard Specifications, as modified herein. They also recognize the delays, expense, and difficulties involved in proving in a legal proceeding the actual loss suffered by the City if the Work is not completed on time. Accordingly, instead of requiring any such proof, the City and the Contractor agree that as liquidated damages or delay (but not as a penalty), the Contractor shall pay the City the sum specified in Section 6-9 of the Special Provisions for each calendar day that expires after the time specified in Article 2, herein. In executing the Agreement, the Contractor acknowledges it has reviewed the provisions of the Standard Specifications, as modified herein, related to

liquidated damages, and has made itself aware of the actual loss incurred by the City due to the inability to complete the Work within the time specified in the Notice to Proceed.

ARTICLE 3 -- CONTRACT PRICE

The City shall pay the Contractor for the completion of the Work, in accordance with the Contract Documents, in current funds the Contract Price(s) named in the Contractor's Bid Proposal and Bid Schedule(s), and any duly authorized Construction Contract Change Orders approved by the City. The amount of the initial contract award in accordance with the Contractor's Bid Proposal is **Thirty Two Thousand Eight Hundred Twenty Six Dollars (\$32,826)**.

Contractor agrees to receive and accept the prices set forth herein, as full compensation for furnishing all materials, performing all work, and fulfilling all obligations hereunder. Said compensation shall cover all expenses, losses, damages, and consequences arising out of the nature of the Work during its progress or prior to its acceptance including those for well and faithfully completing the Work and the whole thereof in the manner and time specified in the Contract Documents; and, also including those arising from actions of the elements, unforeseen difficulties or obstructions encountered in the prosecution of the Work, suspension or discontinuance of the Work, and all other unknowns or risks of any description connected with the Work.

ARTICLE 4 -- THE CONTRACT DOCUMENTS

The Contract Documents consist of the Notice Inviting Bids, Instructions to Bidders, the prevailing rate of per diem wages as determined by the Director of the California Department of Industrial Relations, the accepted Bid and Bid Schedule(s), List of Subcontractors, Local Business Preference Program – Good Faith Efforts, Non-Discrimination Certification, Non-Collusion Declaration, Bidder's General Information, Bid Security or Bid Bond, this Agreement, Worker's Compensation Certificate, Performance Bond, Payment Bond, Standard Specifications, Special Provisions, the Drawings, Addenda numbers 1 to 2, inclusive, and all Construction Contract Change Orders and Work Change Directives which may be delivered or issued after the Effective Date of the Agreement and are not attached hereto.

ARTICLE 5 -- MUTUAL OBLIGATIONS

For and in consideration of the payments and agreements to be made and performed by the City, the Contractor agrees to furnish all materials and perform all work required for the above stated project, and to fulfill all other obligations as set forth in the aforesaid Contract Documents.

City hereby agrees to employ, and does hereby employ, Contractor to provide the materials, complete the Work, and fulfill the obligations according to the terms and conditions herein contained and referred to, for the Contract Price herein identified, and hereby contracts to pay the same at the time, in the manner, and upon the conditions set forth in the Contract Documents.

Contractor specifically acknowledges and agrees to be bound by the Wage Rates and Labor Code requirements specified in the Contract Documents, including the requirement to furnish electronic certified payroll records directly to the Labor Commissioner (via the Division of Labor Standards Enforcement), and shall pay the general prevailing rate of per diem wages as determined by the Director of the Department of Industrial Relations of the State of California.

ARTICLE 6 -- PAYMENT PROCEDURES

The Contractor shall submit Applications for Payment in accordance with the Standard Specifications as amended by the Special Provisions. Applications for Payment will be processed by the City Engineer as provided in the Contract Documents.

ARTICLE 7 -- NOTICES

Whenever any provision of the Contract Documents requires the giving of a written Notice between the parties, it shall be deemed to have been validly given if delivered in person to the individual or to a member of the firm or to an officer of the corporation for whom it is intended, or if delivered at or sent by registered or certified mail, postage prepaid, to the last business address known to the giver of the Notice.

ARTICLE 8 -- INDEMNIFICATION

The Contractor agrees to indemnify and hold harmless the City, and all of its officers and agents from any claims, demands, or causes of action, including related expenses, attorney's fees, and costs, based on, arising out of, or in any way related to the Work undertaken by the Contractor hereunder. This Article 8 incorporates the provisions of Section 7-15 "Indemnification," of the Special Provisions, which are hereby referenced and made a part hereof.

ARTICLE 9 -- NON-DISCRIMINATION

The Contractor represents and agrees that it does not and will not discriminate against any subcontractor, consultant, employee, or applicant for employment because of race, religion, color, sex, or national origin in any matter including without limitation employment upgrading, demotion, transfers, recruitment, recruitment advertising, layoff, termination, rates of pay, or other forms of compensation and selection for training, including apprenticeship.

ARTICLE 10 -- MISCELLANEOUS

Terms used in this Agreement which are defined in the Standard Specifications and the Special Provisions will have the meanings indicated in said Standard Specifications and the Special Provisions. No assignment by a party hereto of any rights under or interests in the Contract Documents will be binding on another party hereto without the written consent of the party sought to be bound; and specifically, but without limitation, monies that may become due and monies that are due may not be assigned without such consent (except to the extent that the effect of this restriction may be limited by law), and unless specifically stated to the contrary in any written consent to an assignment, no assignment will release or discharge the assignor from any duty or responsibility under the Contract Documents.

The City and the Contractor each binds itself, its partners, successors, assigns, and legal representatives, to the other party hereto, its partners, successors, assigns, and legal representatives, in respect of all covenants, agreements, and obligations contained in the Contract Documents.

SIGNATURES ON NEXT PAGE

IN WITNESS WHEREOF, the City and the Contractor have caused this Agreement to be executed the day and year first above written.

**CITY OF PALM SPRINGS,
CALIFORNIA**

APPROVED BY THE CITY COUNCIL:

By _____
David H. Ready
City Manager

Date _____

Agreement No. _____

ATTEST:

By _____
James Thompson
City Clerk

APPROVED AS TO FORM:

By _____
Douglas Holland
City Attorney

RECOMMENDED:

By _____
Marcus L. Fuller, PE, PLS
Assistant City Manager/City Engineer

CONTRACTOR

By: Golden Vista Construction, Inc., dba Golden Valley Construction
Firm/Company Name

By: _____
Signature (notarized)

By: _____
Signature (notarized)

Name: _____

Name: _____

Title: _____

Title: _____

A notary public or other officer completing this certificate verifies only the identity of the individual who signed the document to which this certificate is attached, and not the truthfulness, accuracy or validity of that document.

(This Agreement must be signed in the above space by one having authority to bind the Contractor to the terms of the Agreement.)

(This Agreement must be signed in the above space by one having authority to bind the Contractor to the terms of the Agreement.)

State of _____)
County of _____)ss

State of _____)
County of _____)ss

On _____
before me, _____
personally appeared _____

On _____
before me, _____
personally appeared _____

who proved to me on the basis of satisfactory evidence to be the person(s) whose name(s) is/are subscribed to the within instrument and acknowledged to me that he/she/they executed the same in his/her/their authorized capacity(ies), and that by his/her/their signatures(s) on the instrument the person(s), or the entity upon behalf of which the person(s) acted, executed the instrument.

who proved to me on the basis of satisfactory evidence to be the person(s) whose name(s) is/are subscribed to the within instrument and acknowledged to me that he/she/they executed the same in his/her/their authorized capacity(ies), and that by his/her/their signatures(s) on the instrument the person(s), or the entity upon behalf of which the person(s) acted, executed the instrument.

I certify under PENALTY OF PERJURY under the laws of the State of California that the foregoing paragraph is true and correct.

I certify under PENALTY OF PERJURY under the laws of the State of California that the foregoing paragraph is true and correct.

WITNESS my hand and official seal.

WITNESS my hand and official seal.

Notary Signature:

Notary Signature:

Notary Seal:

Notary Seal:

ATTACHMENT 6

NOTICE OF EXEMPTION

To: Office of Planning and Research
1400 Tenth Street, Room 121
Sacramento, CA 95814

From: City of Palm Springs
3200 E. Tahquitz Canyon Way
Palm Springs, CA 92262

Clerk of the Board
County of Riverside
P.O. Box 751
Riverside, CA 92502-0751

Project Title: Fire Station No. 2, 911 Memorial Improvements City Project No. 15-13

Project Applicant: City of Palm Springs

Project Location (Specific): Fire Station No. 2 located at 300 N. El Cielo Rd., alongside Palm Springs Airport

Project Location (City): City of Palm Springs

Project Location (County): Riverside

Project Description: The scope of work includes exterior and interior improvements including steel tri-pod base for flag pole, steel plasma cut silhouette with concrete base and extension, mirrored tint, custom framing and mounting, printing, and installation of a carved bas relief. The Contractor shall perform minor clearing and grubbing, removal/relocation of trees, relocation of signs, relocation/adjustment of valves, relocation/capping irrigation lines, repairing irrigation emitting devices, repairing bollard lights, relocation of boulders, construct a new concrete sidewalk path, colored stamped concrete, concrete steps and hand railing, reconstruction of driveway and approach, adjustable recessed lighting, exterior accent lighting, flood lights, lighting fixtures on flag pole, LED lamps, boulders, irrigation and planting as well as electrical service connections.

Name of Public Agency Approving Project: City of Palm Springs

Name of Person or Agency Carrying Our Project: City of Palm Springs, Public Works & Engineering Department
3200 E. Tahquitz Canyon Way, Palm Springs, CA 92262

Exempt Status: (check one)

- Ministerial (Sec. 21080(b) (1); 15268);
- Declared Emergency (Sec. 21080(b) (3); 15269(a));
- Emergency Project (Sec. 21080(b) (4); 15269 (b)(c));
- Categorical Exemption. State type and section number: 15301 Class 1 (a),(c) – Existing Facilities
- Statutory Exemptions. State code number:

Reasons why project is exempt: Class 1 consists of operation, repair, maintenance, permitting, leasing, licensing, or minor alteration of existing public or private structures, facilities, mechanical equipment, or topographic features, involving negligible or no expansion of use beyond that existing at the time of the lead agency's determination. Interior or exterior alterations involving such things as interior partitions, plumbing, and electrical conveyances. Existing highways and streets, sidewalks, gutter, bicycle and pedestrian trails, and similar facilities. Therefore, the Fire Station No. 2, 911 Memorial Improvements, City Project No. 15-13, is considered categorically exempt from CEQA.

Lead Agency Contact Person: Savat Khamphou, P.E. **Area Code/Telephone/Extension:** (760) 323-8253, ext. 8744

If filed by applicant:

1. Attach certified document of exemption finding.
2. Has a Notice of Exemption been filed by the public agency approving the project? Yes No

Signature:  **Date:** 6/17/15 **Title:** Asst. Director of Public Works/Asst. City Engineer

Signed by Lead Agency Signed by Applicant

Authority cited: Sections 21083 and 21110, Public Resources Code
Reference: Sections 21108, 21152, and 21152.1, Public Resources Code.

Date received for filing at OPR: _____