



City Council Staff Report

Date: DECEMBER 10, 2008 STUDY SESSION
Subject: SUNLINE BUS SHELTERS
From: City Manager
Initiated By: Director of Public Works/City Engineer

RECOMMENDATION:

- 1) DIRECT STAFF AS APPROPRIATE

STAFF ANALYSIS:

Currently there are 35 bus shelters in Palm Springs. About half were constructed as condition of development and required (in most cases) to architecturally match the proposed development. The remainder are generic shelters matching Sunline's Standards in place at the time of installation.

On October 22, 2008 the Sunline Board of Directors approved a contract for purchase and installation of 100 bus shelters throughout the Coachella Valley. Of these, 19 are scheduled for installation in Palm Springs between January and June 2009. The attachments were provided by Eunice Lovi of Sunline on November 25, 2008 and show the proposed locations and the details of the shelter construction.

Planning Commission and Council had previously conditioned shelters of varying designs but all were structures of concrete block or other structural materials. The ones now proposed by Sunline are aluminum framed with sides of perforated aluminum. They will all be the same, although sizes will vary. Staff is requesting Council discussion and direction concerning Sunline's proposal.

FISCAL IMPACT:

None, if Sunline's proposal is satisfactory to Council. City would be responsible to pay for any bus shelters that varied from the standard if Council was not supportive of the standard plan. Bus shelters are not included in the current budget. If agreement with Sunline provides for advertisements on the shelters, City may benefit from payment for said advertisements.



David J. Barakian
Director of Public Works/City Engineer



David H. Ready
City Manager



Thomas J. Wilson
Assistant City Manager-Development Services

Attachments:

- 1) Map of Bus Shelter Locations (color)
- 2) Various Bus Shelter Plans

BUS STOP IMPROVEMENT PROGRAM - PROPOSED BUS SHELTER LIST

BS #	On Street	Cross Street	Pos. Loc.	Dir.	City	Line(s)	Amenities Needed	Existing Sidewalk Width	Proposed Shelter Type/Size	NON-AD & AD	Proposed Pad Measurements	Improvements Needed	Current Amenities	Phase	Comments
128	Ramon Rd.	Indian Canyon Dr.	NS	SW	EB	P.S.	14 & 30		13FT	AD		N/A	New Bench and Trash	Phase 1	
144	Ramon Rd.	Paseo Dorotea	FS	SE	EB	P.S.	30		9FT	AD		N/A	New Bench and Trash	Phase 2	
178	Ramon Rd.	Paseo Dorotea	MB	NW	WB	P.S.	30		9FT	AD		N/A	New Bench and Trash	Phase 2	
181	El Cielo Rd.	Kirk Douglas Wy.	FS	NE	NB	P.S.	24		13FT	Non-AD	16' L x 4' W		Old Bench and Trash	Phase 2	
203	Rosa Parks Rd.	Granada Ave.	NS	SW	EB	P.S.	24		9FT	Non-AD		N/A	Old Bench and Trash	Phase 1	Existing Pad length - 10FT
213	Palm Canyon Dr.	San Marco Wy.	FS	SW	SB	P.S.	24		13FT	AD		N/A	New Bench and Trash	Phase 1	
228	Rosa Parks Rd.	Granada Ave.	FS	NW	WB	P.S.	24		9FT	Non-AD		N/A	No Amenities	Phase 1	Existing Pad length - 10FT
228	Vista Chino	Gene Aubry Tr.	FS	SE	EB	P.S.	32		13FT	AD		N/A	New Bench and Trash I-Stop	Phase 2	
480	Gene Aubry Tr.	E. Vista Chino	NS	NW	SB	P.S.	14		17FT	AD		N/A	New Bench and Trash I-Stop	Phase 1	
610	Vista Chino	Sunrise Wy.	NS	SW	EB	P.S.	24		13FT	AD		N/A	Old Bench and Trash	Phase 1	
634	E. Palm Canyon Dr.	Barona Rd.	FS	SE	EB	P.S.	111		13FT	AD		N/A	Old Bench and Trash	Phase 2	
635	E. Palm Canyon Dr.	Araby Dr.	FS	SE	EB	P.S.	111		13FT	AD		N/A	New Bench and Trash	Phase 2	
637	E. Palm Canyon Dr.	Cherokee Wy.	FS	SE	EB	P.S.	111		13FT	AD		N/A	New Bench and Trash	Phase 2	
667	Palm Canyon Dr.	Gene Aubry Tr.	FS	NW	WB	P.S.	111		13FT	AD	16' L x 4' W		New Bench and Trash	Phase 2	
738	Sunrise Wy.	Vista Chino	NS	SE	NB	P.S.	24		13FT	AD		N/A	Old Bench and Trash	Phase 1	Existing pad (20' L x 7' W) Sidewalk is cracked and damaged
805	Farell Rd.	E. Vista Chino	NS	SE	NB	P.S.	14		13FT	AD		N/A	Old Bench and Trash	Phase 1	
852	Farell Rd.	E. Vista Chino	FS	SW	SB	P.S.	14		13FT	AD		N/A	Old Bench and Trash	Phase 1	
886	S. Calle Encilla	Ramon Rd.	FS	NE	NB	P.S.	111 & 14 & 30		13FT	Non-AD		N/A	New Bench and Trash	Phase 2	
889	Baristo Rd.	Farell Rd.	NS	SW	EB	P.S.	14 & 24 & 30		17FT	AD		N/A	New Bench and Trash	Phase 1	

Total Number of Bus Stop Recommended for New Shelters = 19
Total Number of Existing Bus Stops = 134
Total Number of Existing Bus Shelters = 35

Shelter Sizes	Phase 1	Phase 2
9 Footer	2	2
13 Footer	6	7
17 Footer	2	0

AD Shelters=	Non-AD Shelters=
Phase 1= 9	Phase 1= 2
Phase 2= 6	Phase 2= 2
9FT NON-AD = 2	9FT AD = 2
13FT NON-AD = 2	13FT AD = 11
17FT NON-AD = 0	17FT AD = 2

SunLine Transit Agency City of Palm Springs Bus Stops

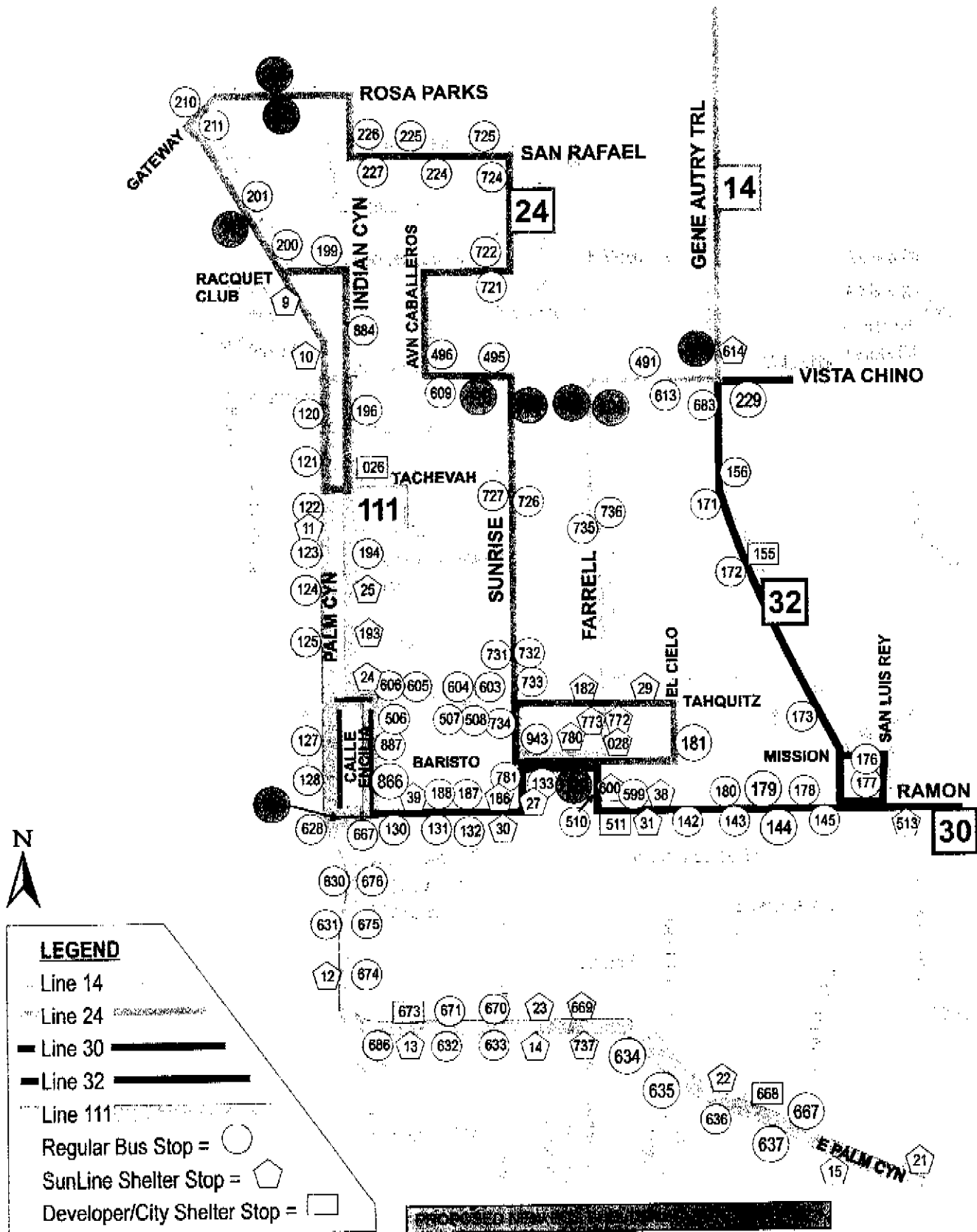

PROPOSED NEW BUS SHELTER LOCATIONS PHASE 2

SUNLINE

CANTILEVERED SHELTERS

6' x 9' Shelter	1-2
6' X 9' Shelter with Ad panel	3-4
6' x 13' Shelter	5-6
6' X 13' Shelter with Ad panel	7-8
6' x 17' Shelter	9-10
6' X 17' Shelter with Ad panel	11-12
6' x 20' Shelter	13-14
6' X 20' Shelter with Ad panel	15-16
5' Bench	17
6' Bench	18
10' Bench	19
12' Bench	20
20 Gal trash receptacle	21
Footing detail	22

Custom Manufacturing
Since 1962



2008 LMI CUSTOMER MANUFACTURING, INC.
12538 CRADDOCK AVE. HAVENHORSE, PA 19326
PHONE 317.979.2160 FAX 317.979.4025
HTTP://WWW.LMISUN.COM

6' x 9' Shelter without Ad Panel



CONTENTS

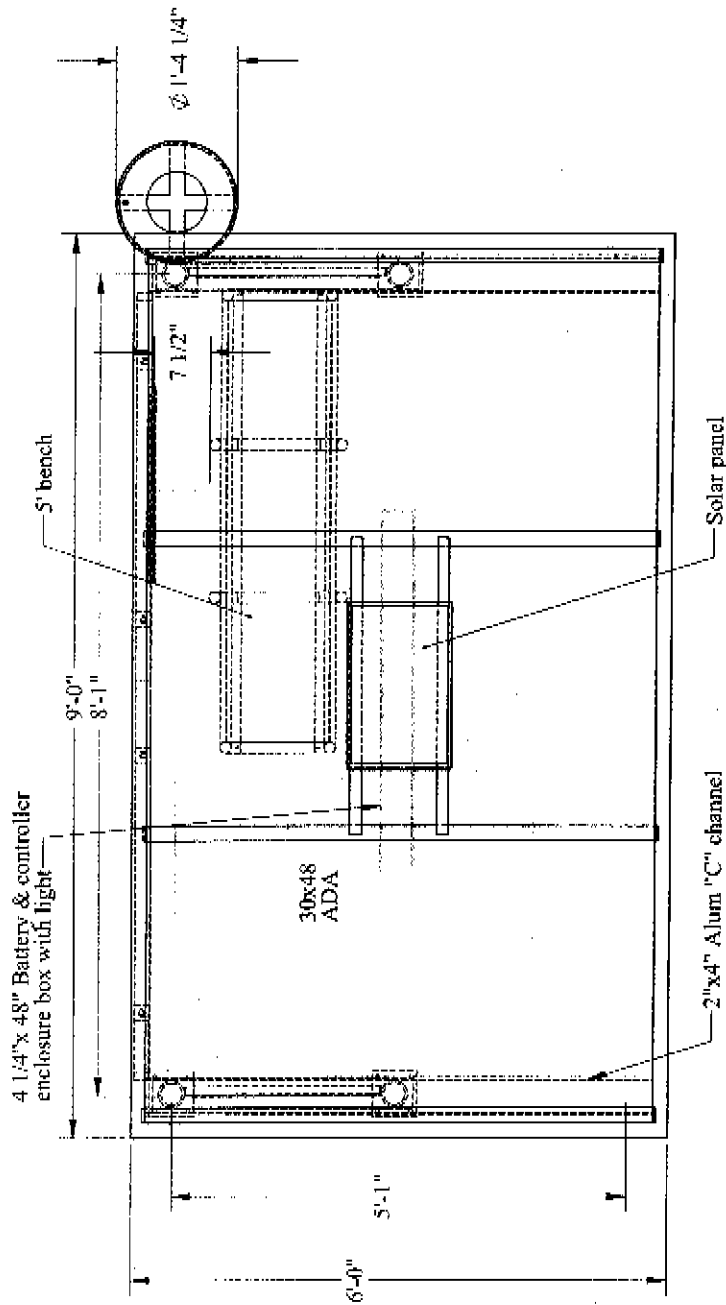

PLAN VIEW
SCALE: 3/4"=1'

CONSTRUCTION

Conforms to all applicable requirements:

Aluminum Association standards for all aluminum parts

ASCE standards.

ANSI load criteria.

AISC steel design

America Welding Society standard D1. 1-80

ASTM A233, class E70XX standards for electrodes

ASTM A-36 for structural steel

ANSI A58.1 of UBC, or applicable local building codes, whichever is more stringent for shelter framing components and fastening method to supporting foundations

Note: all structural framing will be Aluminum 6061; all hardware are from stainless steel

PROJECT NAME: SURVIVE	DRAWING: SCALE: AS SHOWN	APPROVAL: CLIENT	DATE	DISCREPANCY	SHEET
ADDRESS: Various	DRAWN BY: F. Inlante	SALES	RE	BY	1 of 21
CITY/STATE: various	DESIGN DATE: Jun 21 4 2009	CHECKED BY: SALES	RS	BS	
TELEPHONE: na	SALES PERSON: Theresa Roth	PROGRAMMER	RS	BS	
FAX NUMBER: na		ENGINEER	RS	BS	

6' x 9' Shelter without Ad Panel

Finish/Paint/Powder Coat

- (F1) Polyurethane Powder-coated Black and/or T010(S-BL-01)

Materials / Substrate

- (M1) 2x4 LMT aluminum extrusion
- (M2) 1x2x3/16 alum rect tube
- (M3) 3/16" x 2" alum cap
- (M4) 3" alum pipe
- (M5) 2 1/2" alum pipe
- (M6) 6"x6"x3/8" alum plate
- (M7) Perforated Aluminum
- (M8) 1 1/4" alum pipe
- (M9) 2"x 1/2" alum Dial bar
- (M10) 1 1/2" x 1/4" alum angle
- (M11) 0.063" alum sheet

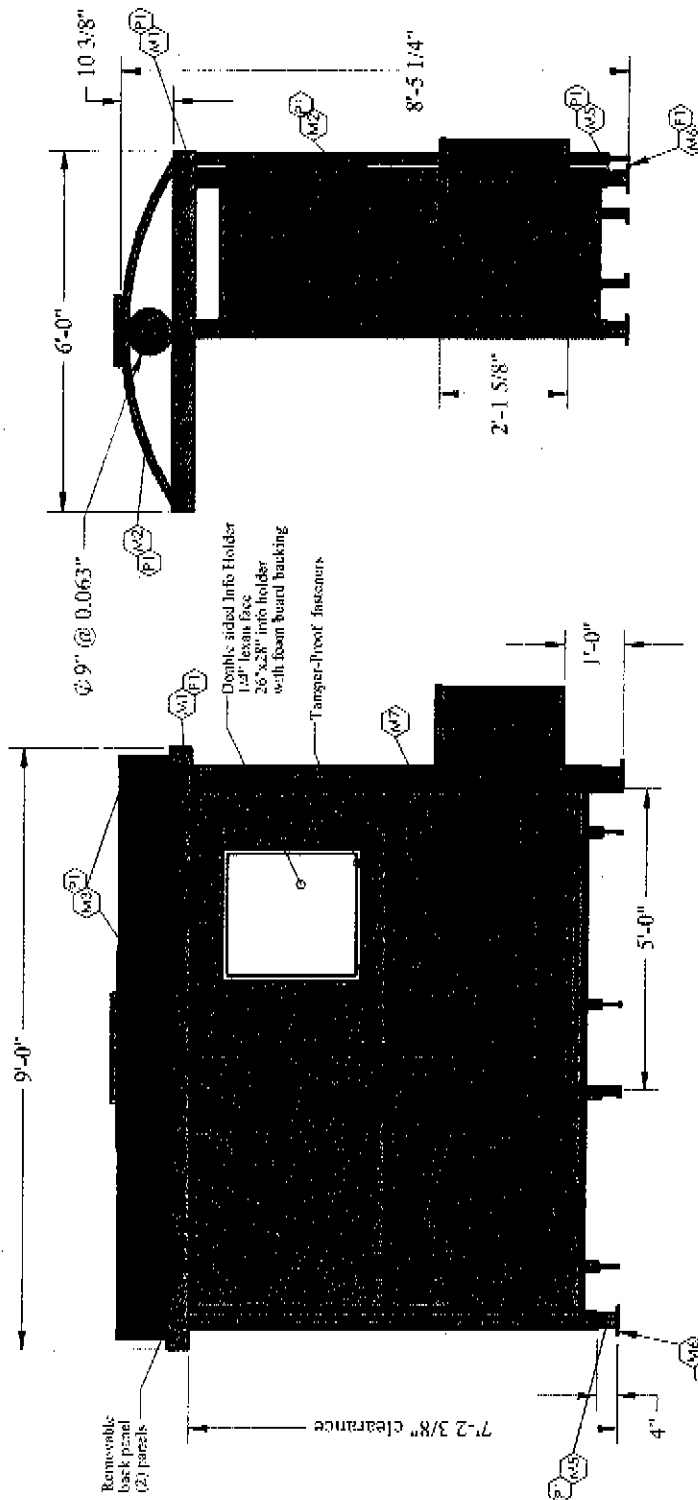

1 FRONT VIEW
SCALE: 1/2"=1'

2 SIDE VIEW
SCALE: 1/2"=1'

PROJECT NAME: SUNBURST	DRAWING: SCALE: AS SHOWN	APPROVAL: CLIENT SALES	DATE	SHEET: 2 OF 21
ADDRESS: Various	DRAWN BY: F. Inlamba	SALES: LANDLORD	DESCRIPTION	
CITY/STATE: Various	DESIGN DATE: Jun**4*2008	PROGRAMMING: ENGINEER	DATE	
TELEPHONE: 000	SALES PERSON: Theresa Roth		R1	
FAX NUMBER: 000			R2	
			R3	
			R4	
			R5	

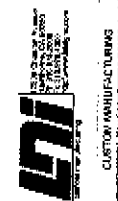

6' x 9' Shelter with Ad Panel

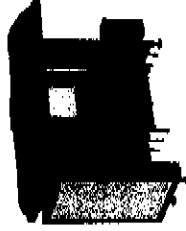

CONTENTS

CONSTRUCTION

- Conforms to all applicable requirements:
- Aluminum Association standards for all aluminum parts
- ASCE standards.
- ANSI load criteria.
- AISC steel design
- America Welding Society standard D1, 1-80
- ASTM A233, class E70XX standards for electrodes
- ASTM A-36 for structural steel
- ANSI A58, I of UBC, or applicable local building codes, whichever is more stringent for shelter framing components and fastening method to supporting foundations

Note: all structural framing will be Aluminum 6061
all hardware are from stainless steel

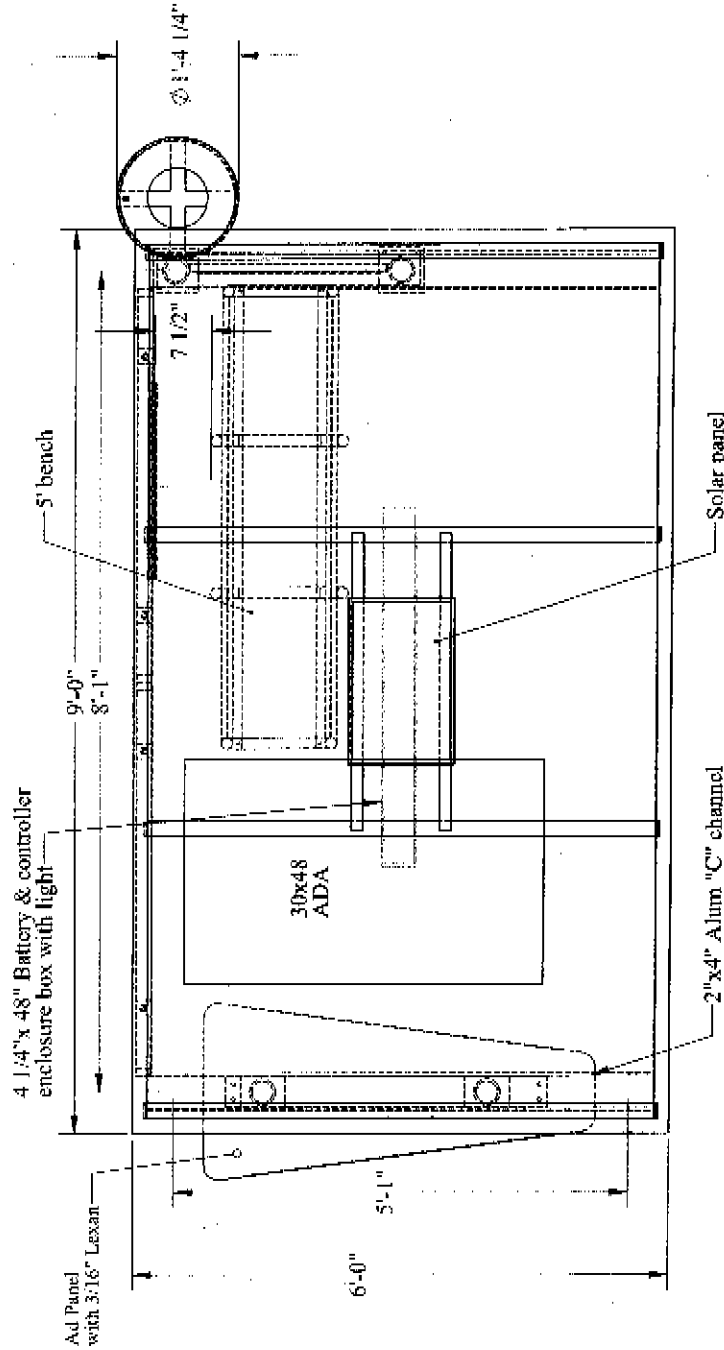

PLAN VIEW
SCALE: 3/4"=1'

PROJECT NAME: SOWLINE	DRAWING: SCALE: AS SHOWN	APPROVAL:	DATE:	DESCRIPTION:	SHEET:
ADDRESS: Various	DESIGNED BY: F. Infante	CLIENT:	BY:		3 of 21
CITY/STATE: Various	DESIGN DATE: Jun-14-2008	SALES:	RS:		
TELEPHONE: n/a	SALES PERSON: Theresa Koch	ENGINEER:	RL:		
FAX NUMBER: n/a					

6' x 9' Shelter with Ad Panel

Finish/Paint/Powder Coat
 Polyurethane Powder-coated
 Blue cardinal TMS-BL01

- Materials / Substrate**
- (M1) 2x4 LxJ aluminum extrusion
 - (M2) 1x2x3/8 alum. rec. tube
 - (M3) 3/16" x 2' alum. cap
 - (M4) 3" alum. pipe
 - (M5) 3/12" alum. pipe
 - (M6) 6"x6"x3/8" Alum. plate
 - (M7) Perforated Aluminum
 - (M8) 1 1/4" alum. pipe
 - (M9) 2' x 1 1/4" alum. flat bar
 - (F10) 1 1/2 x 1/2" alum. angle
 - (M11) 0.063" alum. sheet

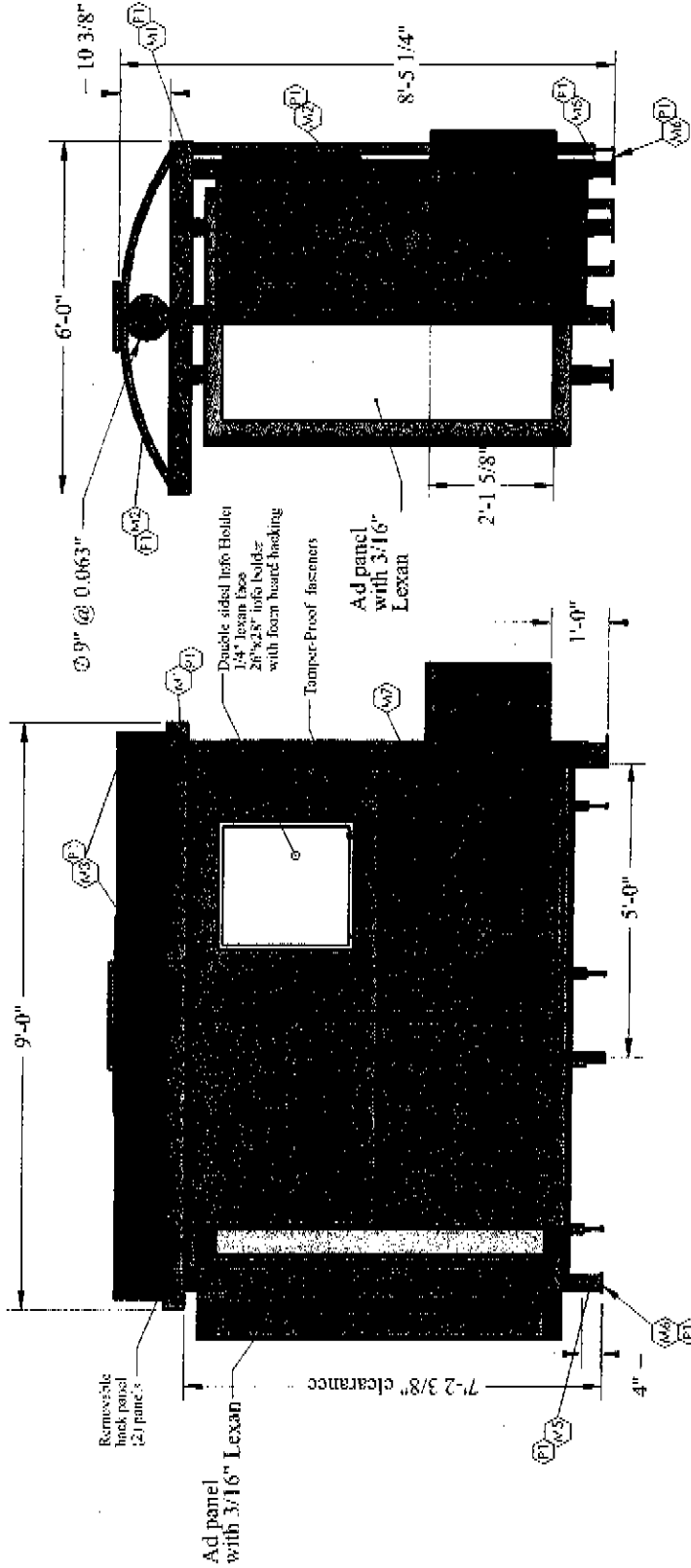

1 FRONT VIEW SCALE: 1/2"=1'

2 SIDE VIEW SCALE: 1/2"=1'

PROJECT NAME: SUMME		DRAWING: SCALE: AS SHOWN		APPROVAL: DATE		DATE: DESCRIPTION		SHEET: 4 OF 21	
ADDRESS: Various		DRAWN BY: E. Filante		CLIENT: SALES		BY: RS		DESIGNED BY: SALES	
CITY/STATE: Various		DESIGN DATE: Jun 14 2008		LANDLORD: PROGRAMMING		BY: RS		CHECKED BY: SALES	
TELEPHONE: rvb		SALES PERSON: Theresa Roth		ENGINEER: ENGINEER		BY: RS		GENERAL NOTES: 1. ALL DIMENSIONS ARE TO FACE UNLESS OTHERWISE NOTED. 2. ALL DIMENSIONS ARE TO FACE UNLESS OTHERWISE NOTED. 3. ALL DIMENSIONS ARE TO FACE UNLESS OTHERWISE NOTED. 4. ALL DIMENSIONS ARE TO FACE UNLESS OTHERWISE NOTED.	
FAX NUMBER: rvb									

6' x 13' Shelter without Ad Panel

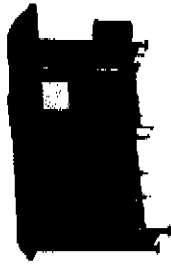

CONTENTS

CONSTRUCTION

- Conforms to all applicable requirements:
- Aluminum Association standards for all aluminum parts
- ASCE standards.
- ANSI load criteria.
- AISC steel design
- America Welding Society standard D1. 1-80
- ASTM A233, class E70XX standards for electrodes
- ASTM A-36 for structural steel?
- ANSI A58. 1 of UBC, or applicable local building codes, whichever is more stringent for shelter framing components and fastening method to supporting foundations

Note: all structural framing will be Aluminum 6061 all hardware are from stainless steel

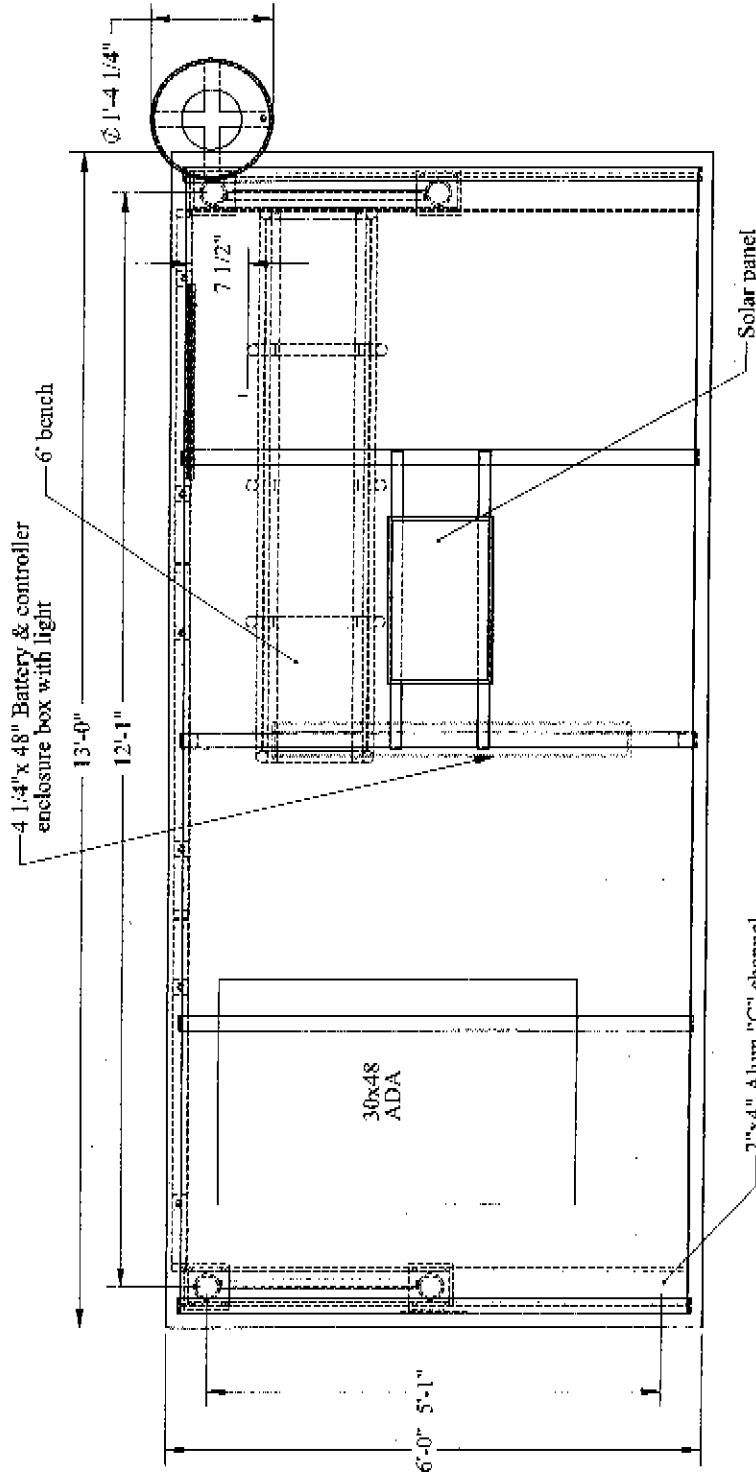

1 PLAN VIEW
SCALE: 3/4"=1'

PROJECT NAME: SOLARLINE	DRAWING:	APPROVAL:	DATE:	DESCRIPTION:	SHEET:
ADDRESS: Various	SCALE: AS SHOWN	CLIENT:	R1		5 of 21
CITY/STATE: Various	DRAWN BY: F. Infante	SALES:	R2		
TELEPHONE: 03	DESIGN DATE: Jan 17 2008	ANGLONO	R3		
FAX NUMBER: 03	SALES PERSON: Theresa Rod	PROGRAMMING	R4		
		ENGINEER	R5		
			GENERAL NOTES: 1. ALL DIMENSIONS ARE IN FEET AND INCHES UNLESS OTHERWISE NOTED. 2. ALL MATERIALS SHALL BE AS SPECIFIED OR APPROVED BY THE ARCHITECT. 3. ALL WORK SHALL BE IN ACCORDANCE WITH THE LATEST EDITIONS OF THE BUILDING CODES AND STANDARDS. 4. THE CONTRACTOR SHALL BE RESPONSIBLE FOR OBTAINING ALL NECESSARY PERMITS. 5. THE CONTRACTOR SHALL MAINTAIN ACCESS TO ALL UTILITIES AT ALL TIMES. 6. ALL WORK SHALL BE COMPLETED WITHIN THE SPECIFIED TIME FRAME. 7. THE CONTRACTOR SHALL BE RESPONSIBLE FOR PROTECTING ALL EXISTING UTILITIES AND STRUCTURES. 8. ALL MATERIALS SHALL BE STORED PROPERLY AND PROTECTED FROM THE ELEMENTS. 9. THE CONTRACTOR SHALL MAINTAIN A NEAT AND ORDERLY WORK SITE AT ALL TIMES. 10. ALL WORK SHALL BE SUBJECT TO INSPECTION AND APPROVAL BY THE ARCHITECT.		

6' x 13' Shelter without Ad Panel

Finish/Paint/Powder Coat
 Polyurethane Powder-Coated
 Base color: T1009-BL03

- Materials / Substrate**
- (M1) 2x4 LNI aluminum extrusion
 - (M2) 1x2x3/16 alum. sec. fl. bar
 - (M3) 2.1x6" x 2" alum. cap
 - (M4) 3" alum. pipe
 - (M5) 2.1x2" alum. pipe
 - (M6) 6"x6"x2.8" alum. plate
 - (M7) Perforated Aluminum
 - (M8) 1.1x4" alum. pipe
 - (M9) 2"x 1.4" alum. flat bar
 - (M10) 1" x 2" x 1.4" alum. angle
 - (M11) 0.063" alum. sheet

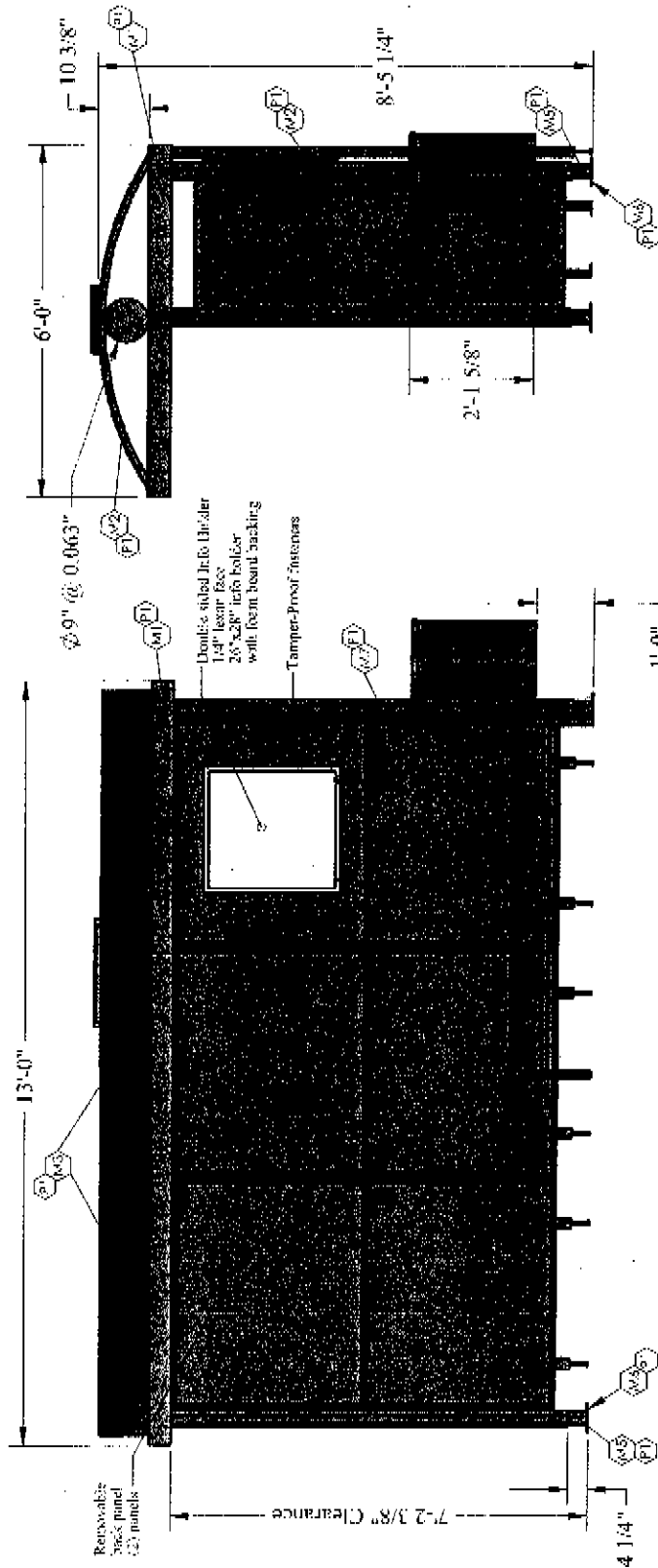

FRONT VIEW
 SCALE: 1/2"=1'

SIDE VIEW
 SCALE: 1/2"=1'

PROJECT NAME: SUNLINE	DRAWING:	DATE:	DESCRIPTION:	SHEET:
ADDRESS: Various	SCALE: AS SHOWN	R1		6 OF 21
CITY/STATE: Various	DRAWN BY: F. Infante	R2		
TELEPHONE: n/a	DESIGN DATE: 06*14*2008	R3		
FAX NUMBER: n/a	SALES PERSON: Theresa Roth	R4		
		R5		



GENERAL NOTES
 1. ALL DIMENSIONS ARE IN UNITS OF INCHES UNLESS OTHERWISE SPECIFIED.
 2. ALL DIMENSIONS ARE TO FACE UNLESS OTHERWISE SPECIFIED.
 3. ALL DIMENSIONS ARE TO CENTERLINE UNLESS OTHERWISE SPECIFIED.
 4. ALL DIMENSIONS ARE TO CENTERLINE UNLESS OTHERWISE SPECIFIED.
 5. ALL DIMENSIONS ARE TO CENTERLINE UNLESS OTHERWISE SPECIFIED.

6' x 13' Shelter with Ad Panel

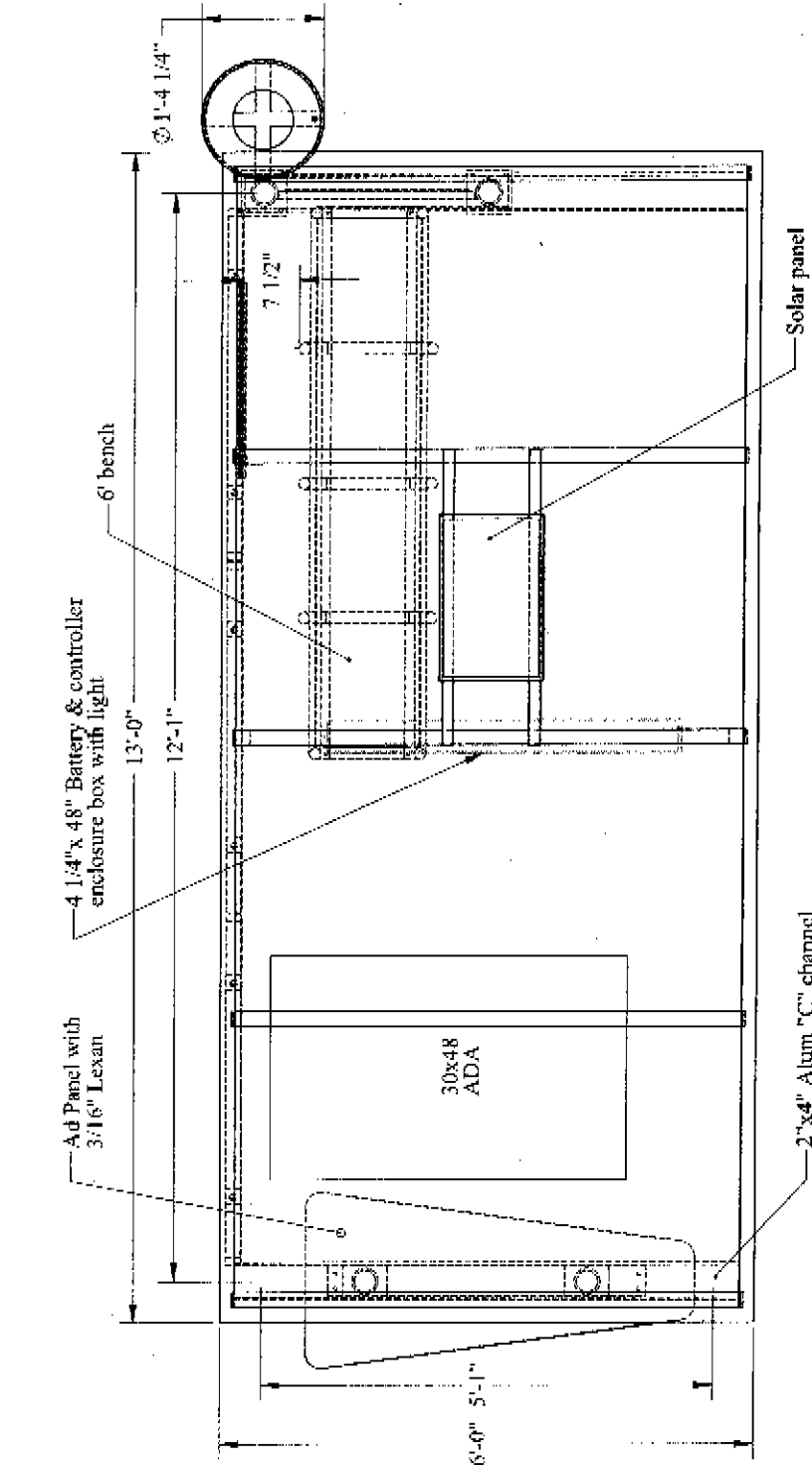

PLAN VIEW
SCALE: 3/4"=1'



CONTENTS

CONSTRUCTION

- Conforms to all applicable requirements:
- Aluminum Association standards for all aluminum parts
- ASCE standards
- ANSI load criteria
- AIISC steel design
- America Welding Society standard D1. 1-80
- ASTM A233, class E70XX standards for electrodes
- ASTM A-36 for structural steel
- ANSI A58.1 of LBC, or applicable local building codes, whichever is more stringent for shelter framing components and fastening method to supporting foundations

Note: all structural framing will be Aluminum 6061 all hardware are from stainless steel

PROJECT NAME: SUN/WE		DRAWING:		APPROVAL:		DATE		BY		DESCRIPTION	
ADDRESS: Various		SCALE: AS SHOWN		CLIENT:		RT		RT		SHEET	
CITY/STATE: Various		DRAWN BY: F. Friano		SALES:		RC		RC		7 of 21	
TELEPHONE: (43)		DESIGN DATE: Jun-12-2008		LAB/ORD:		R3		R3		GENERAL NOTES	
FAX NUMBER: (43)		SALES PERSON: Theresa Roth		PROGRAMING:		R4		R4		GENERAL NOTES	
				DESIGNER:		R5		R5		GENERAL NOTES	
				CHECKER:						GENERAL NOTES	
				DESIGNER AND BUILDER OF SIGAS:						GENERAL NOTES	
				DESIGNER:						GENERAL NOTES	

6' x 13' Shelter with Ad Panel

Finish/Paint/Powder Coat
 Polyurethane Powder-Coated
 Blue cardinal: 3100-BL01

Materials / Substrate

- (M1) 2x2 DMT aluminum extrusion
- (M2) 3/2x3 1/2 aluminum extrusion
- (M3) 1 1/4" x 2" aluminum pipe
- (M4) 3" aluminum pipe
- (M5) 2 1/2" aluminum pipe
- (M6) 6 3/8" x 3/8" aluminum plate
- (M7) Perforated Aluminum
- (M8) 1 1/4" aluminum pipe
- (M9) 2 x 1 1/4" aluminum bar
- (M10) 1 1/2" x 1 1/4" aluminum angle
- (M11) 0.063" aluminum sheet

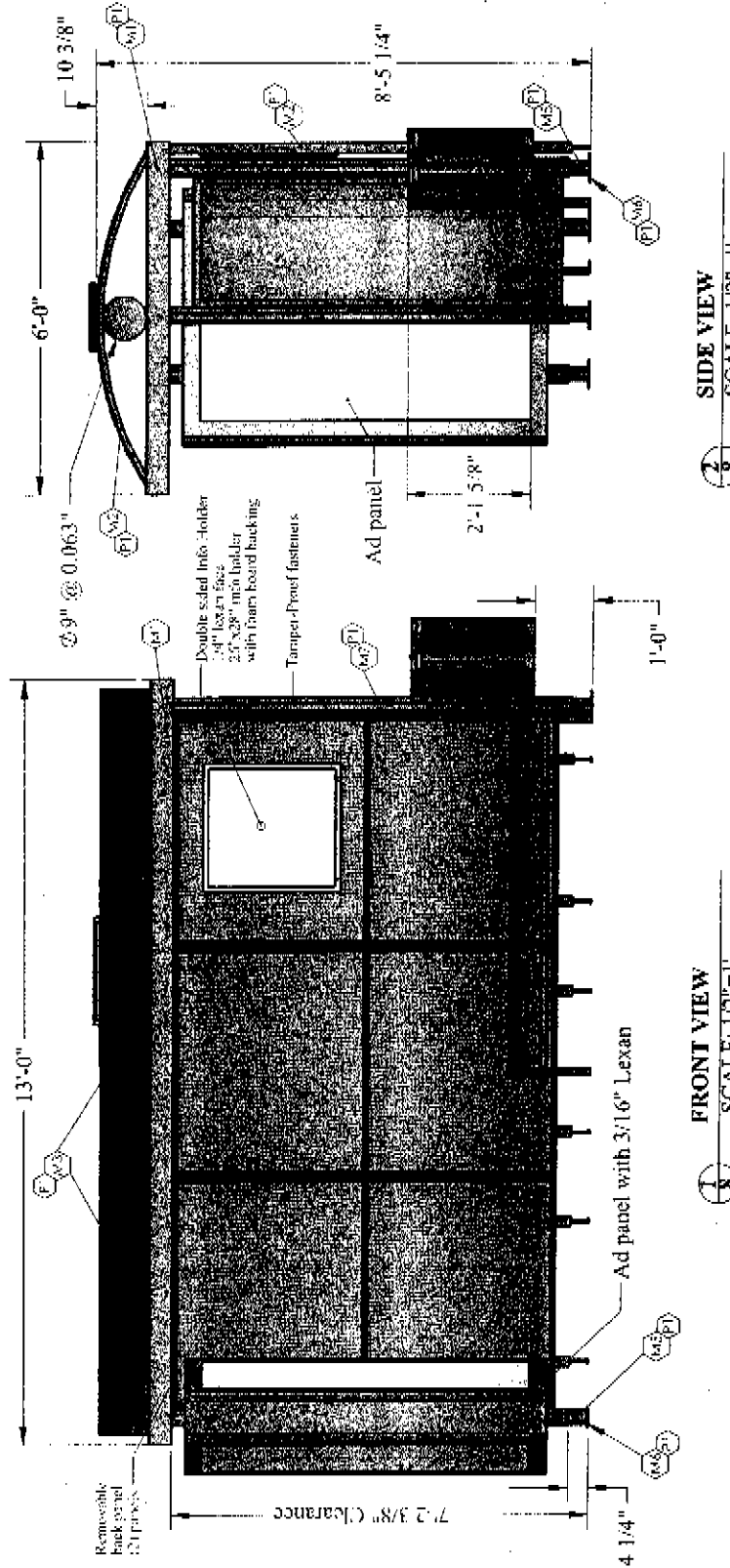

FRONT VIEW
 SCALE: 1/2"=1'

SIDE VIEW
 SCALE: 1/2"=1'

PROJECT NAME: SONLINE		DRAWING: SCALE: AS SHOWN		APPROVAL:		DATE:		BY:		DESCRIPTION:		SHEET: 8 OF 21	
ADDRESS: Various		DRAWN BY: E. Imantib		CLIENT:		R1		R2				NOTES: ORIGINAL OWNER: BIRMINGHAM, ALABAMA. THIS DRAWING IS FOR THE ORIGINAL PROJECT ONLY. IT IS NOT TO BE USED FOR ANY OTHER PROJECTS WITHOUT THE WRITTEN PERMISSION OF THE ORIGINAL OWNER.	
CITY/STATE: Various		DESIGN DATE: Jul 14 2008		LANDLORD:		R3		R4				GENERAL NOTES: 1. WORK SHALL BE DONE IN ACCORDANCE WITH THE CITY OF BIRMINGHAM PERMITS AND ORDINANCES. 2. ALL MATERIALS SHALL BE NEW UNLESS OTHERWISE SPECIFIED. 3. THE CONTRACTOR SHALL BE RESPONSIBLE FOR OBTAINING ALL NECESSARY PERMITS. 4. THE CONTRACTOR SHALL MAINTAIN ACCESS TO ALL ADJACENT PROPERTIES AT ALL TIMES.	
TELEPHONE: n/a		SALES PERSON: Theresa Roth		PROGRAMMER:		R5		R6				CUSTOMER: LMI	
FAX NUMBER: n/a				ENGINEER:									

6' x 17' Shelter without Ad Panel



CONTENTS

CONSTRUCTION

- Conforms to all applicable requirements:
- Aluminum Association standards for all aluminum parts
- ASCE standards
- ANSI load criteria.
- AISC steel design
- American Welding Society standard DI, 1-80
- ASTM A233, class E70XX standards for electrodes
- ASTM A-36 for structural steel
- ANSI A58.1 of LRC, or applicable local building codes, whichever is more stringent for shelter framing components and fastening method to supporting foundations

Note: all structural framing will be Aluminum 6061 all hardware are from stainless steel

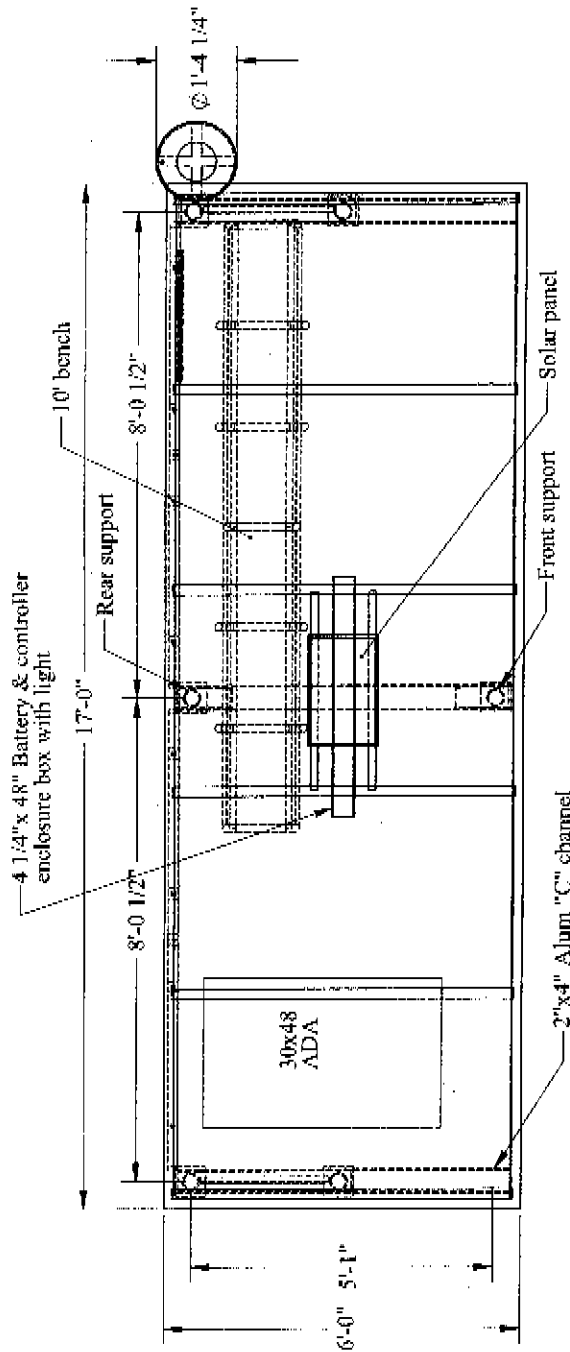

PLAN VIEW
SCALE: 3/4"=1'

PROJECT NAME: Various	DRAWING: AS SHOWN	APPROVAL: CLIENT	DATE: F1	DESCRIPTION: SHEET
ADDRESS: Various	SCALE: AS SHOWN	SALES: LANDLORD	DATE: F2	DESCRIPTION: SHEET
CITY/STATE: Various	DRAWN BY: E. Infante	PROGRAMMING: ENGINEER	DATE: F3	DESCRIPTION: SHEET
TELEPHONE: NA	DESIGN DATE: Jun-17-2008		DATE: F4	DESCRIPTION: SHEET
FAX NUMBER: NA	SALES PERSON: Theresa Ann		DATE: F5	DESCRIPTION: SHEET



9 of 21

6' x 17' Shelter without Ad Panel

Finish/Paint/Powder Coat
 Polyurethane Dioxide-Coated
 Blue sandalwood (D999-BL01)

Materials / Substrate

- (M1) 2x4 LND aluminum extrusion
- (M2) 1x2x3-16 alum. rec. tube
- (M3) 1/2" x 2" alum. cap
- (M4) 3" alum pipe
- (M5) 2 1/2" alum pipe
- (M6) 6"x6"x3/4" Alum plate
- (M7) Perforated Aluminum
- (M8) 1 1/4" alum pipe
- (M9) 2"x 1 1/4" alum flat bar
- (M10) 1 1/2" x 1 1/4" alum angle
- (M11) 0.063" alum sheet

Double sided Jello Dishes
 1.5" lexan face
 26"x28" jello holder
 w/4" foam "sand backing"

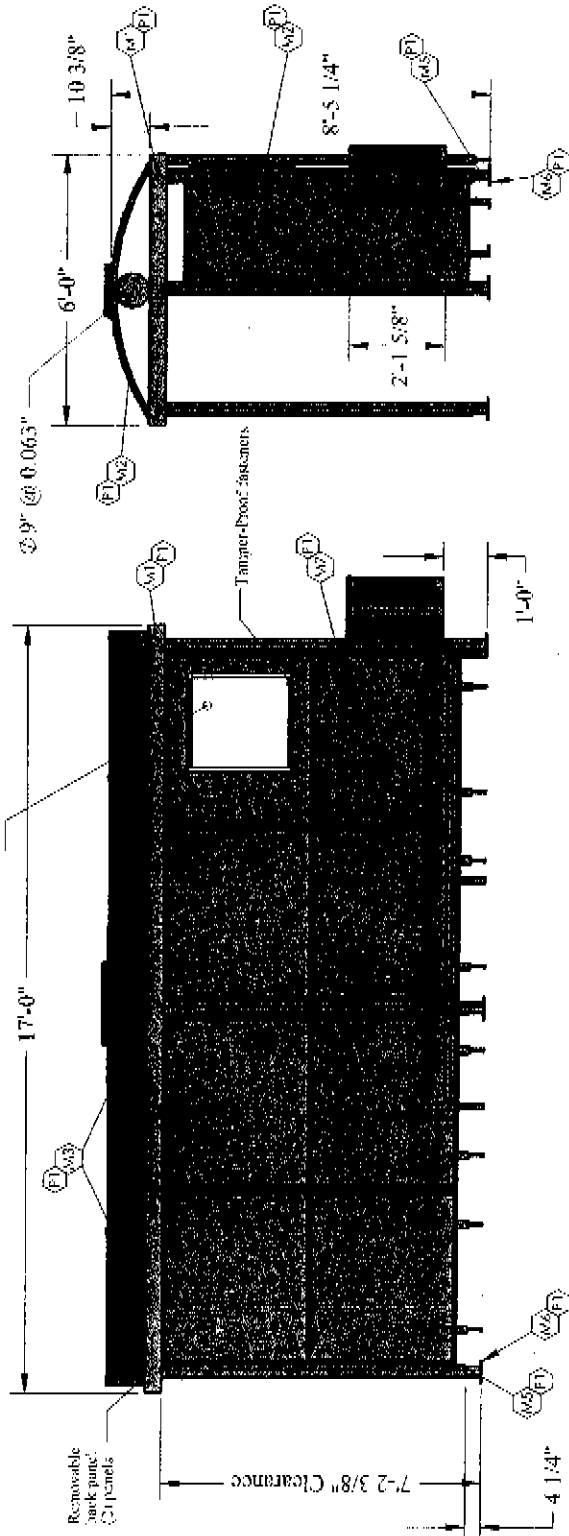

1 FRONT VIEW
 SCALE: 3/8"=1'

2 SIDE VIEW
 SCALE: 3/8"=1'

PROJECT NAME: SUNLINE	DRAWING: SALES	APPROVAL: SALES	DATE: 06/17/2008	BY: SALES	DESCRIPTION: 10 OF 21	SHEET: 10 OF 21
ADDRESS: Various	SCALE: AS SHOWN	CUSTOMER: SALES	DATE: 06/17/2008	BY: SALES	DESCRIPTION: 10 OF 21	SHEET: 10 OF 21
CITY/STATE: various	DRAWN BY: F. Infante	DESIGNER: SALES	DATE: 06/17/2008	BY: SALES	DESCRIPTION: 10 OF 21	SHEET: 10 OF 21
TELEPHONE: NA	DESIGN DATE: 06/17/2008	SALES PERSON: Theresa Roth	DATE: 06/17/2008	BY: SALES	DESCRIPTION: 10 OF 21	SHEET: 10 OF 21
FAX NUMBER: NA	SALES PERSON: Theresa Roth	DATE: 06/17/2008	BY: SALES	DESCRIPTION: 10 OF 21	SALES PERSON: Theresa Roth	DATE: 06/17/2008

GENERAL NOTES

1. ALL DIMENSIONS ARE IN UNITS OF INCHES UNLESS OTHERWISE SPECIFIED.

2. ALL DIMENSIONS ARE TO FACE UNLESS OTHERWISE SPECIFIED.

3. ALL DIMENSIONS ARE TO CENTERLINE UNLESS OTHERWISE SPECIFIED.

4. ALL DIMENSIONS ARE TO CENTERLINE UNLESS OTHERWISE SPECIFIED.

5. ALL DIMENSIONS ARE TO CENTERLINE UNLESS OTHERWISE SPECIFIED.

6. ALL DIMENSIONS ARE TO CENTERLINE UNLESS OTHERWISE SPECIFIED.

7. ALL DIMENSIONS ARE TO CENTERLINE UNLESS OTHERWISE SPECIFIED.

8. ALL DIMENSIONS ARE TO CENTERLINE UNLESS OTHERWISE SPECIFIED.

9. ALL DIMENSIONS ARE TO CENTERLINE UNLESS OTHERWISE SPECIFIED.

10. ALL DIMENSIONS ARE TO CENTERLINE UNLESS OTHERWISE SPECIFIED.

6' x 17' Shelter with Ad Panel

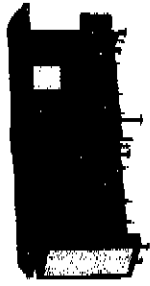

CONTENTS

CONSTRUCTION

- Confirms to all applicable requirements:
- Aluminum Association standards for all aluminum parts
- ASCE standards.
- ANSI load criteria.
- AISC steel design
- American Welding Society standard D1. 1-80
- ASTM A233, class E70XX standards for electrodes
- ASTM A-36 for structural steel
- ANSI A58, 1 of UBC, or applicable local building codes, whichever is more stringent for shelter framing components and fastening method to supporting foundations

Note: all structural framing will be Aluminum 6061
all hardware are from stainless steel

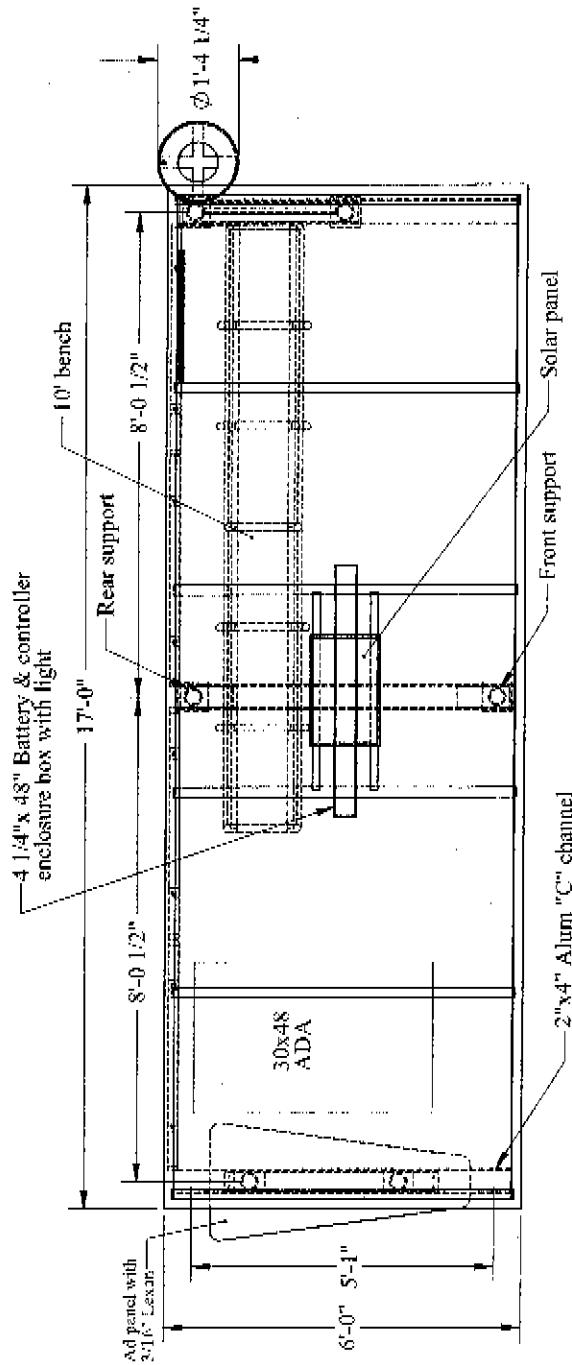

PLAN VIEW
SCALE: 3/4"=1'

PROJECT NAME: SUNLINE	DRAWING:	APPROVAL:	DATE	DESCRIPTION	SHEET
ADDRESS: Various	SCALE: AS SHOWN	CLIENT	R1		11 of 21
CITY/STATE: Various	DRAWN BY: F. Itzard	SALES	R2		
TELEPHONE: T/B	DESIGN DATE: 6/17/2008	LANDSCAPE	R3		
FAK NUMBER: T/B	SALES PERSON: Theresa Roth	PROGRAMING	R4		
		ENGINEER	R5		



6' x 17' Shelter with Ad Panel

Finish/Paint/Powder Coat

- (PI) Polyethylene Powder-Coated Blue anodized T6061-BL.F.

Materials / Substrate

- (M1) 2x4 LxH aluminum extrusion
- (M2) 1x2x3/16 alum rear tube
- (M3) 3/16" x 2" alum cap
- (M4) 3" alum pipe
- (M5) 2 1/2" alum pipe
- (M6) 6"x6"x3/8" Alum plate
- (M7) Perforated Aluminum
- (M8) 1 1/4" alum pipe
- (M9) 2"x 1 1/4" alum flat bar
- (M10) 1 1/2"x 1/4" alum angle
- (M11) 0.063" alum sheet

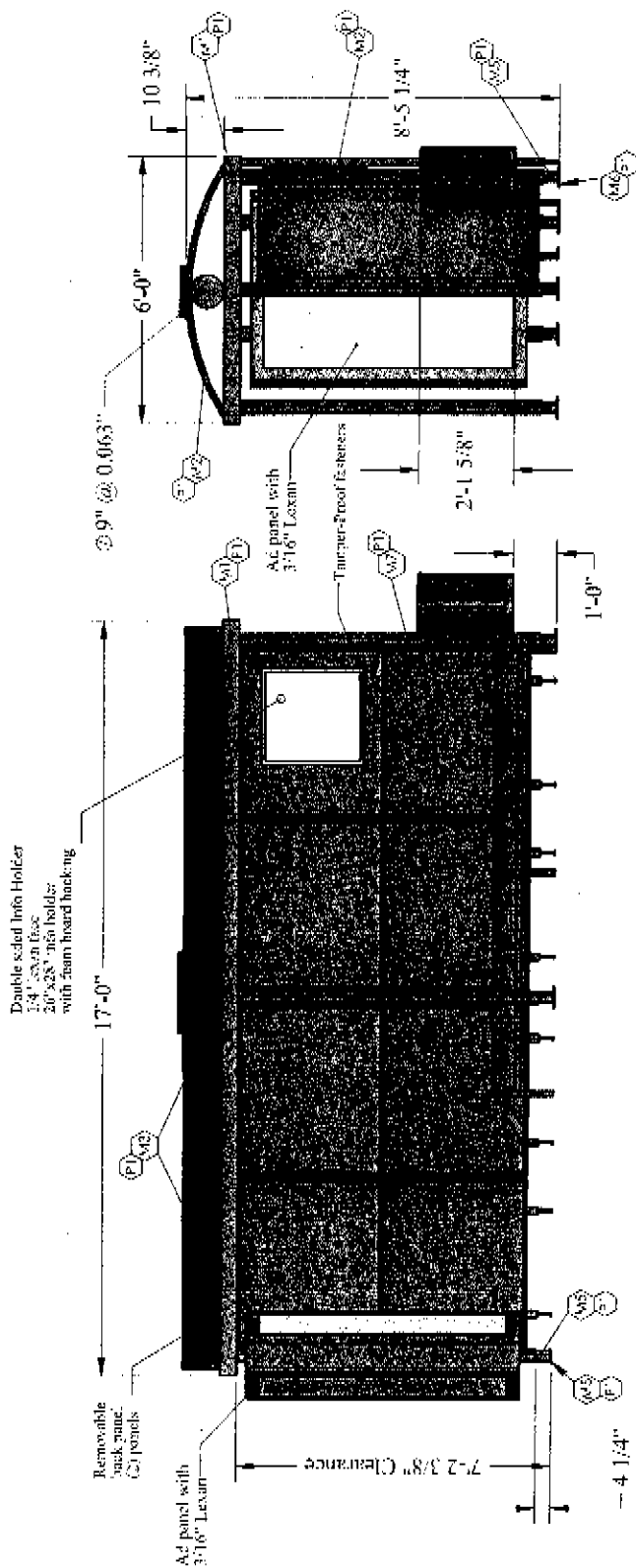

1 FRONT VIEW
SCALE: 3/8"=1'

2 SIDE VIEW
SCALE: 3/8"=1'

PROJECT NAME: SUNLIFE	APPROVAL:	DATE:	DESCRIPTION:	SHEET:
ADDRESS: Various	CLIENT:	B1		12 OF 21
CITY/STATE: various	SALES:	B2		
TELEPHONE: n/a	LAURELLO	B3		
FAX NUMBER: n/a	PROGRAMING	B4		
	ENGINEER	B5		
	SALES PERSON: Theresa Rom			
	DESIGN DATE: 06/17/2008			
	SALES PERSON: Theresa Rom			
	ENGINEER			
	PROGRAMING			
	SALES			
	CLIENT			
	SCALE: AS SHOWN			
	SCALE: 3/8"=1'			
	DRAWING:			

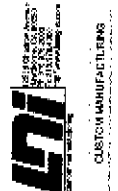

6' x 20' Shelter without Ad Panel

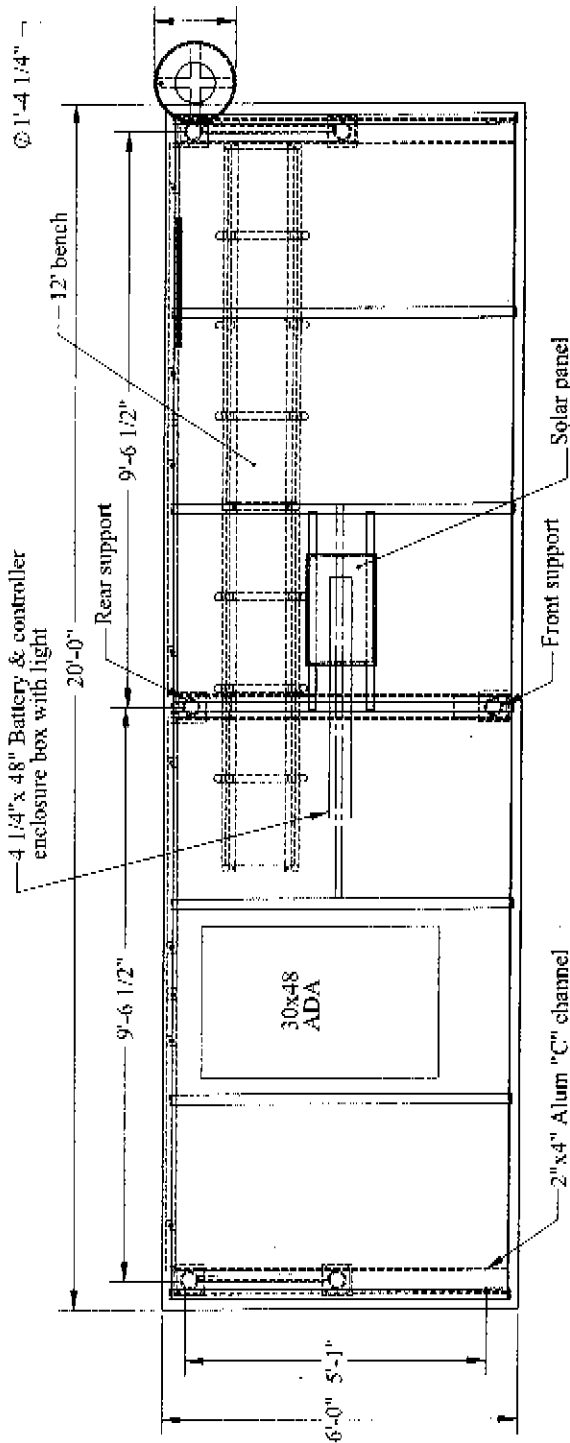

⑬ PLAN VIEW
SCALE: 3/4"=1'

CONSTRUCTION

- Conforms to all applicable requirements;
- Aluminum Association standards for all aluminum parts
- ASCE standards
- ANSI load criteria.
- AISC steel design
- American Welding Society standard D1. 1-80
- ASTM A233, class E70XX standards for electrodes
- ASTM A-36 for structural steel
- ANSI A58.1 of UBC, or applicable local building codes, whichever is more stringent for shelter framing components and fastening method to supporting foundations

Note: all structural framing will be Aluminum 6061 all hardware are from stainless steel

PROJECT NAME: SHEDS	DRAWING:	APPROVAL:	DATE:	DESCRIPTION:
ADDRESS: Various	SCALE: AS SHOWN	CLIENT:	P1	
CITY/STATE: Various	DRAWN BY: F. Infante	SALES:	P2	
TELEPHONE: 713	DESIGN DATE: Jul 19*2008	LAUNDRY:	P3	
FAX NUMBER: 618	SALES PERSON: Theresa Roth	PROGRAMMING:	P4	
		ENGINEER:	P5	
			SHEET 13 of 21	
GENERAL NOTES: 1. ALL DIMENSIONS ARE TO FACE UNLESS OTHERWISE SPECIFIED. 2. ALL MATERIALS SHALL BE NEW UNLESS OTHERWISE SPECIFIED. 3. ALL FASTENERS SHALL BE STAINLESS STEEL UNLESS OTHERWISE SPECIFIED. 4. ALL ELECTRICAL WIRING SHALL BE IN ACCORDANCE WITH THE NATIONAL ELECTRICAL CODE (NEC). 5. ALL STRUCTURAL STEEL SHALL BE ASTM A36 UNLESS OTHERWISE SPECIFIED. 6. ALL ALUMINUM SHALL BE 6061-T6 UNLESS OTHERWISE SPECIFIED. 7. ALL WELDING SHALL BE IN ACCORDANCE WITH THE AMERICAN WELDING SOCIETY (AWS) D1.1.				

6' x 20' Shelter without Ad Panel

Finish/Paint/Powder Coat
 Polyurethane Powder-Coated
 Blue cathod. (1009-BL01)

Materials / Substrate

- (M1) 2x4x4x1 aluminum extrusion
- (M2) 2x2x3/16 aluminum rest tube
- (M3) 3/16" x 2" alum. cap
- (M4) 3" alum pipe
- (M5) 2 1/2" alum pipe
- (M6) 6"x6"x3/8" Alum plate
- (M7) Perforated Aluminum
- (M8) 1" x 4" alum pipe
- (M9) 2" x 4" alum flat bar
- (M10) 1 1/2" x 1/2" alum angle
- (M11) 0.063" alum sheet

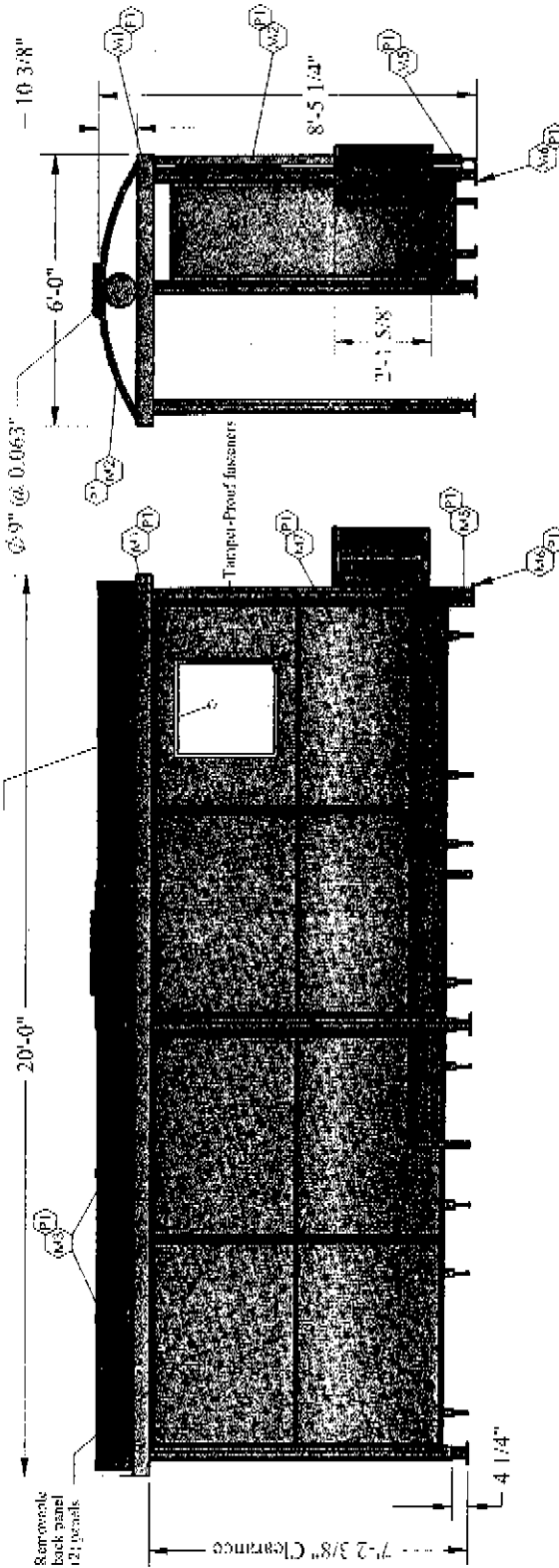

FRONT VIEW
 SCALE: 3/8"=1'

SIDE VIEW
 SCALE: 3/8"=1'

PROJECT NAME: SUNLINE
 ADDRESS: Various
 CITY/STATE: various
 TELEPHONE: 774
 FAX NUMBER: N/A

DRAWING: SCALE: AS SHOWN
 DRAWN BY: F. Imhoff
 DESIGN DATE: Jul'18-2008
 SALES PERSON: Theresa Roth

APPROVAL
 FILED SALES
 LAMORRO
 PROGRAMMER
 ENGINEER

DATE



DATE BY DESCRIPTION
 R1
 R2
 R3
 R4
 R5

FOR THE EXAMINATION OF THE PROPOSAL, THE DRAWING SHALL BE KEPT IN THE OFFICE OF THE ARCHITECT AND NOT TO BE REPRODUCED OR COPIED IN ANY MANNER WITHOUT THE WRITTEN CONSENT OF THE ARCHITECT.
GENERAL NOTES
 DRAWING IS TO BE CONSIDERED COMPLETE UNLESS OTHERWISE NOTED.
 ALL DIMENSIONS ARE TO FACE UNLESS OTHERWISE NOTED.
 ALL DIMENSIONS ARE TO FACE UNLESS OTHERWISE NOTED.
 SHEET 14 OF 21

6' x 20' Shelter with Ad Panel



CONTENTS

CONSTRUCTION

- Conforms to all applicable requirements:
- Aluminum Association standards for all aluminum parts
- ASCE standards.
- ANSI lead criteria.
- AISC steel design
- America Welding Society standard D1. 1-80
- ASTM A233, class E70XX standards for electrodes
- ASTM A-36 for structural steel
- ANSI A58, I of UBC, or applicable local building codes, whichever is more stringent for shelter framing components and fastening method to supporting foundations

Note: all structural framing will be Aluminum 6061 all hardware are from stainless steel

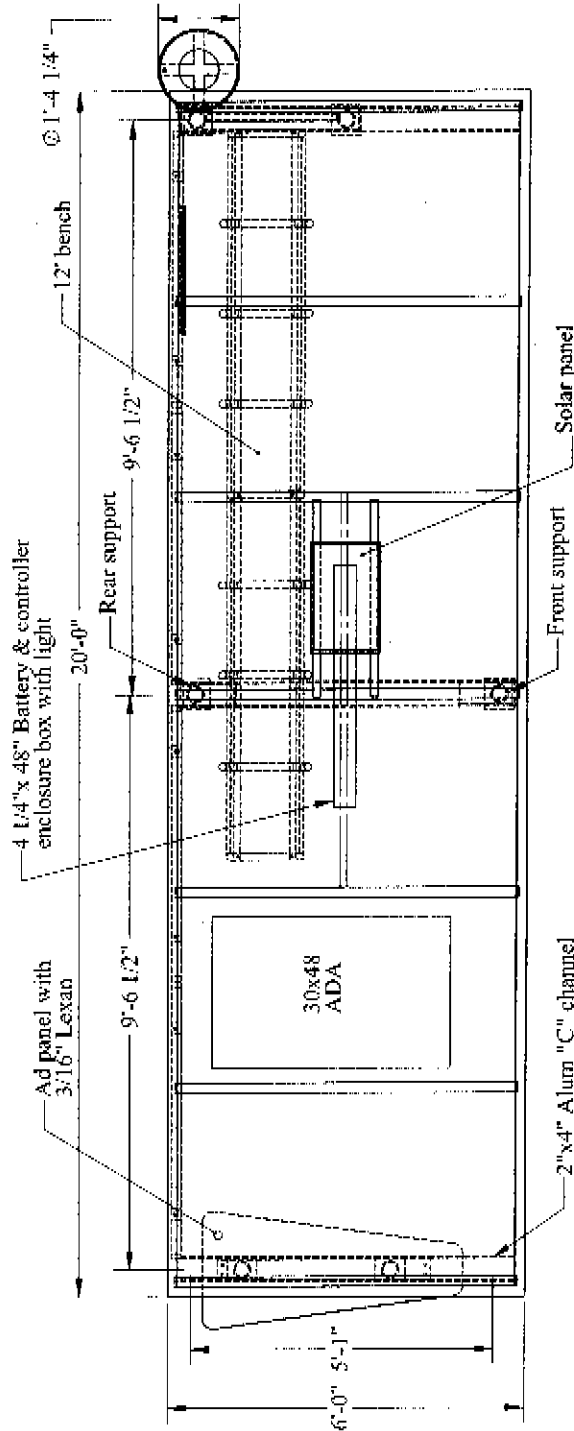

PLAN VIEW
SCALE: 3/4"=1'

PROJECT NAME: SCUMLINE	DRAWING: SCALE: AS SHOWN	APPROVAL: C-LEIT	DATE	DESCRIPTION	SHEET
ADDRESS: Various	DRAWN BY: F. Infante	SALES: UNRECORDED	R1		
CITY/STATE: various	DESIGN DATE: 10/18/2008	PROGRAMMIS: ENGINEER	R2		
TELEPHONE: n/a	SALES PERSON: Theresa Rott		R3		
FAX NUMBER: n/a			R4		
			R5		
<p>GENERAL NOTES</p> <p>1. ALL DIMENSIONS ARE TO FACE UNLESS OTHERWISE NOTED.</p> <p>2. ALL MATERIALS SHALL BE AS SPECIFIED OR APPROVED BY THE ARCHITECT.</p> <p>3. ALL FABRICATION SHALL BE IN ACCORDANCE WITH THE MANUFACTURER'S INSTRUCTIONS.</p> <p>4. ALL WELDING SHALL BE IN ACCORDANCE WITH THE WELDER'S QUALIFICATION AND THE WELDING CODE.</p> <p>5. ALL FASTENERS SHALL BE STAINLESS STEEL UNLESS OTHERWISE NOTED.</p>				<p>15 of 21</p>	

6' x 20' Shelter with Ad Panel

Finish/Paint/Powder Coat
 Polyurethane Powder-Coated
 Blue anodized: 3049-BL01

Materials / Substrate

- (M1) 3x3 L1 aluminum extrusion
- (M2) 1x2x3/8 aluminum tube
- (M3) 3/16 x 2" allen cap
- (M4) 2" aluminum pipe
- (M5) 2 1/2" allen caps
- (M6) 6' x 6' x 3/8" aluminum plate
- (M7) perforated 4lb aluminum
- (M8) 1 1/2" aluminum pipe
- (M9) 2" x 1 1/2" allen bar bar
- (M10) 1 1/2" x 1 1/2" allen angle
- (M11) 8.065" allen sheet

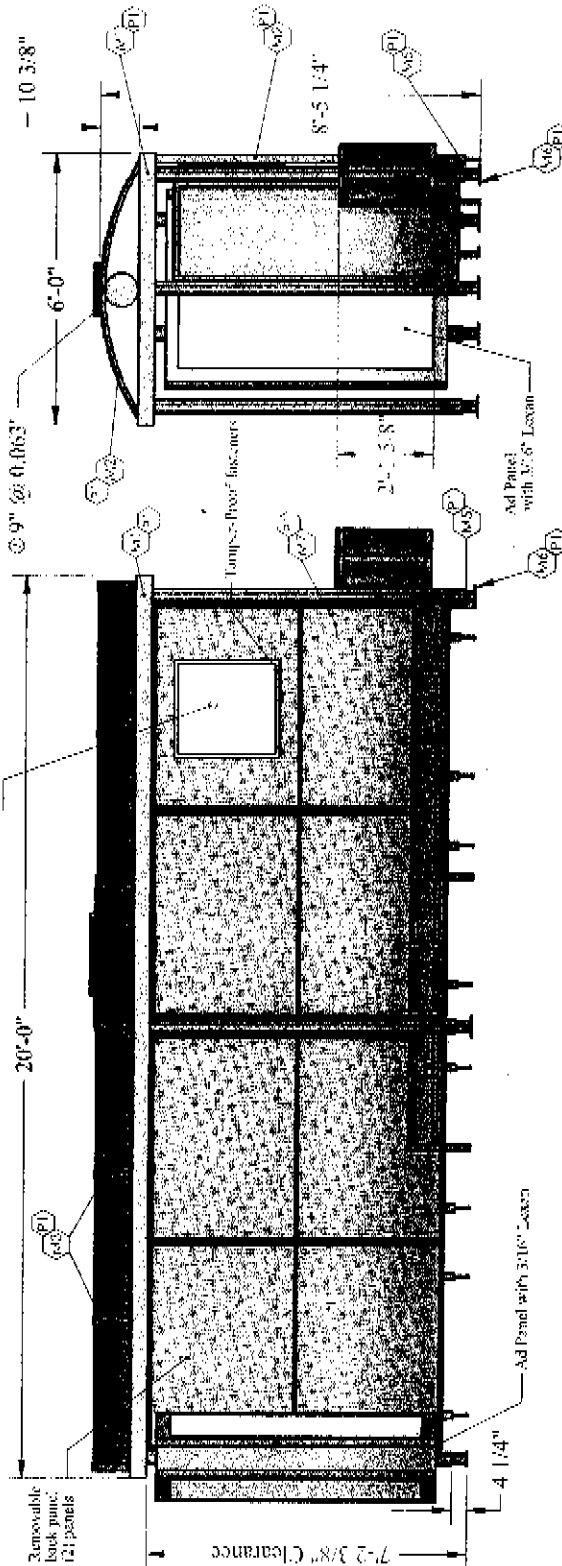

1 FRONT VIEW
 SCALE: 3/8"=1'

2 SIDE VIEW
 SCALE: 3/8"=1'

PROJECT NAME: SOWANE		APPROVAL		DATE		DESCRIPTION	
ADDRESS: Various	SCALE: AS SHOWN	SUBP	DATE	BY	DESCRIPTION	SHEET	
CITY/STATE: Various	DRAWN BY: E. Ingle	SALES	R1			16 OF 21	
TELEPHONE: 704	DESIGN DATE: Jan-18-2008	LANDROD	R2			GENERAL NOTES	
FAX NUMBER: 704	SALES PERSON: Theresa Roth	PROGRAMING	R3			SEE LIST OF MATERIALS FOR SPECIFICATIONS	
		EMERK	R4			SEE LIST OF MATERIALS FOR SPECIFICATIONS	
			R5			SEE LIST OF MATERIALS FOR SPECIFICATIONS	

5' Bench

Finish/Paint/Powder Coat

- ② Blue cathodic TPOB-BL01
- ⑤① 2x4 LMI aluminum extrusion
- ⑤② 1x2x3/16 alum flat bars
- ⑤③ 3/16" x 2" alum cap
- ⑤④ 3" alum pipe
- ⑤⑤ 2 1/2" alum pipe
- ⑤⑥ 6"x6"x8" alum plate
- ⑤⑦ Perforated Aluminum
- ⑤⑧ 1 1/2" alum pipe
- ⑤⑨ 2 x 1 1/4" alum flat bar
- ⑤⑩ 1 1/2" x 1/4" alum angle
- ⑤⑪ 0.063" alum sheet

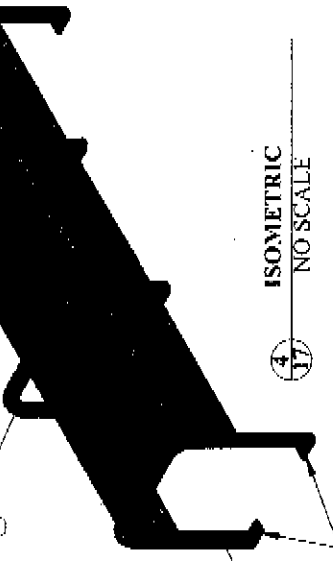

④ ISOMETRIC
⑪ NO SCALE

1/4" plate will 1/2" hole be secured to concrete

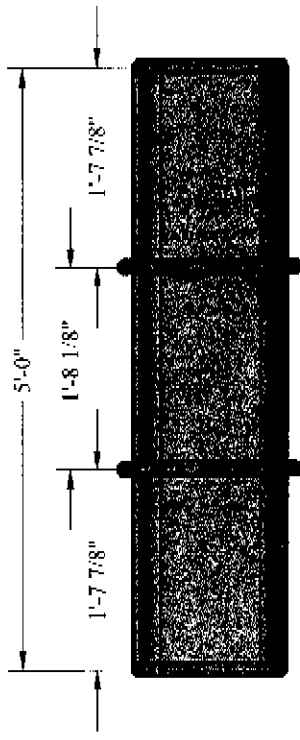

① TOP VIEW
⑪ SCALE: 1"=1'

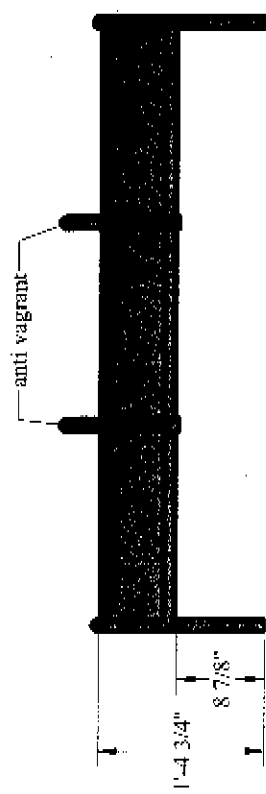

⑦ FRONT VIEW
⑪ SCALE: 1/2"=1'

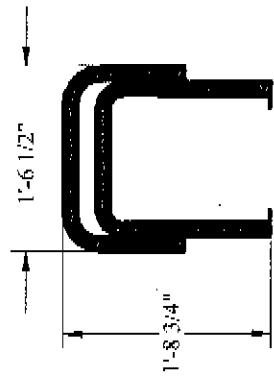

⑧ SIDE VIEW
⑪ SCALE: 1"=1'

NOTE: The bench shall be Thermo Plastic Coated

PROJECT NAME: SUNLINE	APPROVAL:	DATE:	DESCRIPTION:	SHEET:
ADDRESS: Various	SCALE: AS SHOWN	CLIENT:		
CITY/STATE: Various	DRAWN BY: F. Infante	P1:		
TELEPHONE: n/a	DESIGN DATE: Jun 04-2008	P2:		
FAX NUMBER: n/a	SALES PERSON: Thomas Rom	P3:		
	PROGRAMMER: ENGINEER	P4:		
		P5:		

GENERAL NOTES

1. ALL DIMENSIONS ARE TO FACE UNLESS OTHERWISE NOTED.

2. ALL MATERIALS SHALL BE SUPPLIED BY THE MANUFACTURER.

3. ALL MATERIALS SHALL BE FINISHED WITH A POWDER COAT FINISH.

4. ALL MATERIALS SHALL BE FINISHED WITH A POWDER COAT FINISH.

5. ALL MATERIALS SHALL BE FINISHED WITH A POWDER COAT FINISH.

6. ALL MATERIALS SHALL BE FINISHED WITH A POWDER COAT FINISH.

7. ALL MATERIALS SHALL BE FINISHED WITH A POWDER COAT FINISH.

8. ALL MATERIALS SHALL BE FINISHED WITH A POWDER COAT FINISH.

9. ALL MATERIALS SHALL BE FINISHED WITH A POWDER COAT FINISH.

10. ALL MATERIALS SHALL BE FINISHED WITH A POWDER COAT FINISH.

LMI
CUSTOM MANUFACTURING

6' Bench

Finish/Paint/Powder Coat

- (M1) Black coat/ral Thermo-PLAST
- (M2) 2x4 LND aluminum extrusion
- (M3) 1x2x3/16 alum. rod tube
- (M4) 3/4" x 2" alum. cap
- (M5) 3" alum pipe
- (M6) 2 1/2" alum pipe
- (M7) 6" x 6" x 8" alum plate
- (M8) Perforated Aluminum
- (M9) 1 1/2" alum pipe
- (M10) 2x 1 1/4" alum flat bar
- (M11) 1.25x 1.25 alum angle
- (M12) 0.063" alum sheet

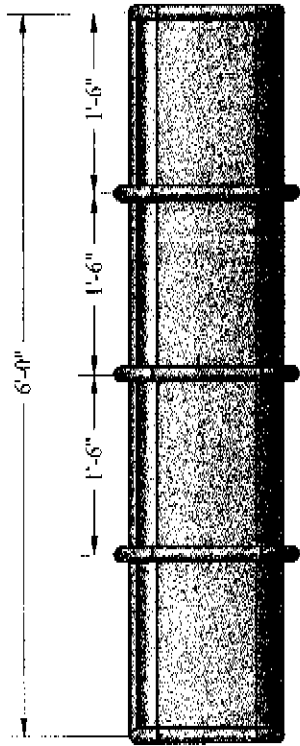

1 TOP VIEW
SCALE: 1"=1'

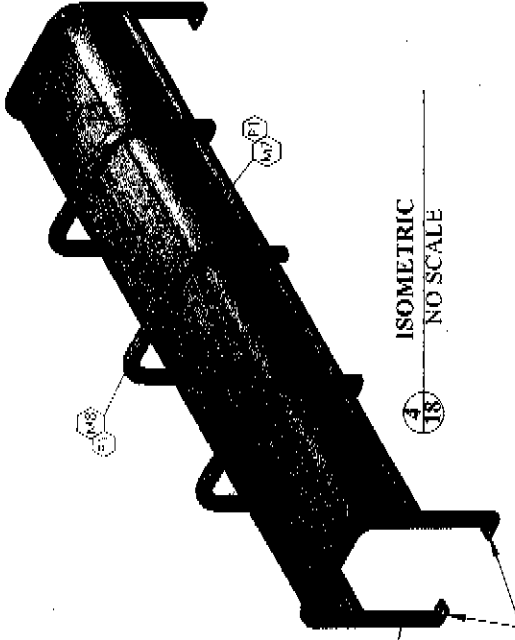

4 ISOMETRIC
NO SCALE

1/4" plate with 1/2" hole to secure to concrete

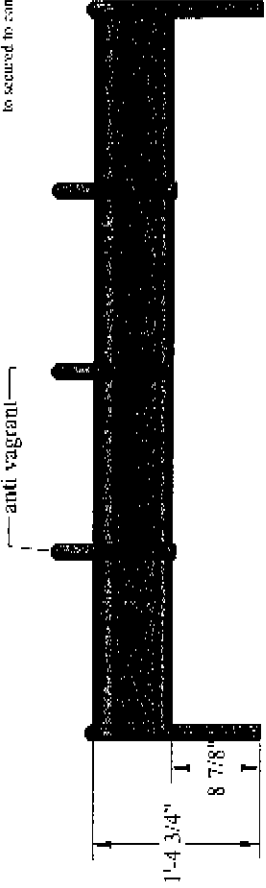

2 FRONT VIEW
SCALE: 1/2"=1'

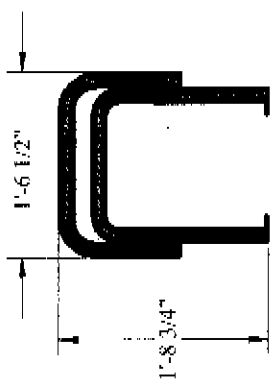

3 SIDE VIEW
SCALE: 1"=1'

NOTE: The bench shall be Thermo Plastic Coated

PROJECT NAME: SORLINE	DRAWING: 2	APPROVAL: 18	DATE: 18	DESCRIPTION: 3	SHEET: 18 OF 22
ADDRESS: Various	SCALE: AS SHOWN	CLIENT: SALES	DATE: R1	DESCRIPTION: R2	GENERAL NOTES: SEE THIS DRAWING FOR ALL DIMENSIONS AND MATERIALS TO BE USED. ALL DIMENSIONS ARE TO FACE UNLESS OTHERWISE SPECIFIED. ALL MATERIALS ARE TO BE OF THE HIGHEST QUALITY AVAILABLE.
CITY/STATE: Various	DRAWN BY: F. Inlake	DESIGNED: J. Inlake	DATE: R3	DESCRIPTION: R4	GENERAL NOTES: SEE THIS DRAWING FOR ALL DIMENSIONS AND MATERIALS TO BE USED. ALL DIMENSIONS ARE TO FACE UNLESS OTHERWISE SPECIFIED. ALL MATERIALS ARE TO BE OF THE HIGHEST QUALITY AVAILABLE.
TELEPHONE: 703	DESIGN DATE: Jun '04	PROGRAMS: 18	DATE: R4	DESCRIPTION: R5	GENERAL NOTES: SEE THIS DRAWING FOR ALL DIMENSIONS AND MATERIALS TO BE USED. ALL DIMENSIONS ARE TO FACE UNLESS OTHERWISE SPECIFIED. ALL MATERIALS ARE TO BE OF THE HIGHEST QUALITY AVAILABLE.
SAY NUMBER: 703	SALES PERSON: Theresa Roth	ENGINEER: 18	DATE: R5	DESCRIPTION: R6	GENERAL NOTES: SEE THIS DRAWING FOR ALL DIMENSIONS AND MATERIALS TO BE USED. ALL DIMENSIONS ARE TO FACE UNLESS OTHERWISE SPECIFIED. ALL MATERIALS ARE TO BE OF THE HIGHEST QUALITY AVAILABLE.

10' Bench

Finish/Paint/Powder Coat

- (F) Black finish / Epoxy-PUR

Materials / Substrate

- (M1) 3rd LMI aluminum extrusion
- (M2) 1x2x3/16" alum. xsect tube
- (M3) 3/8" x 3/8" alum. cap
- (M4) 3" alum. pipe
- (M5) 2 1/2" alum pipe
- (M6) 6"x8"x3/8" alum plate
- (M7) Perforated Aluminum
- (M8) 1 1/4" alum pipe
- (M9) 2"x 1/4" alum flat bar
- (M10) 1 1/2"x 1/4" alum angle
- (M11) 6363 alum sheet

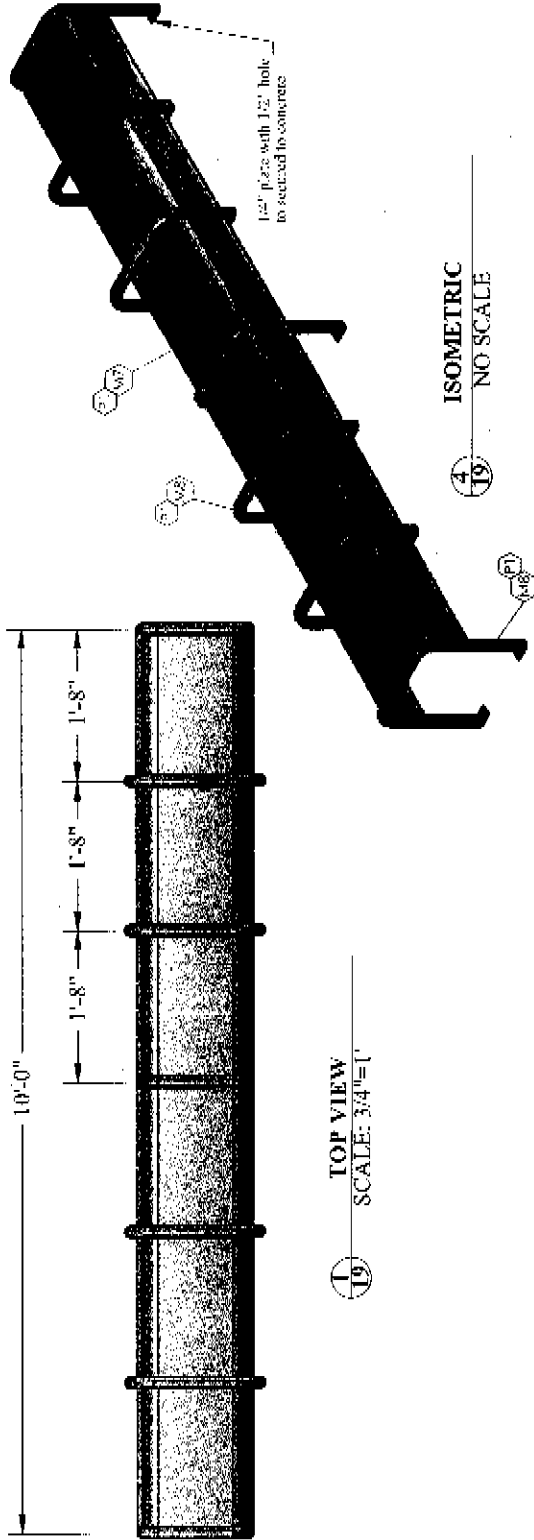

1
19
TOP VIEW
SCALE: 3/4"=1'

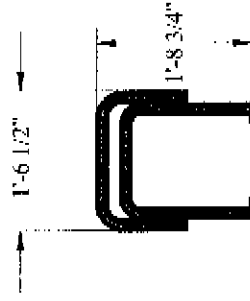

3
19
SIDE VIEW
SCALE: 1"=1'

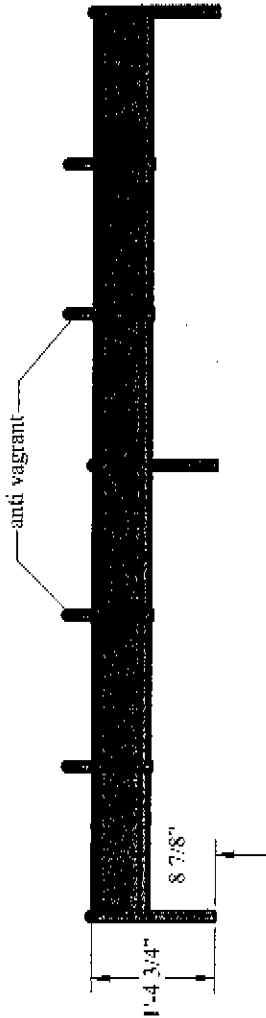

2
19
FRONT VIEW
SCALE: 1/2"=1'

NOTE: The bench shall be Thermo Plastic Coated

PROJECT NAME: SCVLONE	DRAWING: SCALE: AS SHOWN	APPROVAL: CLIENT	DATE: R1	DESCRIPTION:	SHEET: 19 OF 22
ADDRESS: Various	DRAWN BY: F. Inance	SALES	R2		
CITY/STATE: various	DESIGN DATE: Jul '08 * 2008	LAMINATED	R3		
TELEPHONE: 409	SALES PERSON: Theresia Roof	PROGRAMMING	R4		
FAX NUMBER: 03	ENGINEER	CUSTOM MANUFACTURING	R5		

GENERAL NOTES

1. ALL DIMENSIONS ARE TO FACE UNLESS OTHERWISE SPECIFIED.

2. ALL MATERIALS SHALL BE SUPPLIED BY THE MANUFACTURER.

3. ALL MATERIALS SHALL BE SUPPLIED BY THE MANUFACTURER.

4. ALL MATERIALS SHALL BE SUPPLIED BY THE MANUFACTURER.

5. ALL MATERIALS SHALL BE SUPPLIED BY THE MANUFACTURER.

6. ALL MATERIALS SHALL BE SUPPLIED BY THE MANUFACTURER.

7. ALL MATERIALS SHALL BE SUPPLIED BY THE MANUFACTURER.

8. ALL MATERIALS SHALL BE SUPPLIED BY THE MANUFACTURER.

9. ALL MATERIALS SHALL BE SUPPLIED BY THE MANUFACTURER.

10. ALL MATERIALS SHALL BE SUPPLIED BY THE MANUFACTURER.

11. ALL MATERIALS SHALL BE SUPPLIED BY THE MANUFACTURER.

12. ALL MATERIALS SHALL BE SUPPLIED BY THE MANUFACTURER.

13. ALL MATERIALS SHALL BE SUPPLIED BY THE MANUFACTURER.

14. ALL MATERIALS SHALL BE SUPPLIED BY THE MANUFACTURER.

15. ALL MATERIALS SHALL BE SUPPLIED BY THE MANUFACTURER.

16. ALL MATERIALS SHALL BE SUPPLIED BY THE MANUFACTURER.

17. ALL MATERIALS SHALL BE SUPPLIED BY THE MANUFACTURER.

18. ALL MATERIALS SHALL BE SUPPLIED BY THE MANUFACTURER.

19. ALL MATERIALS SHALL BE SUPPLIED BY THE MANUFACTURER.

20. ALL MATERIALS SHALL BE SUPPLIED BY THE MANUFACTURER.

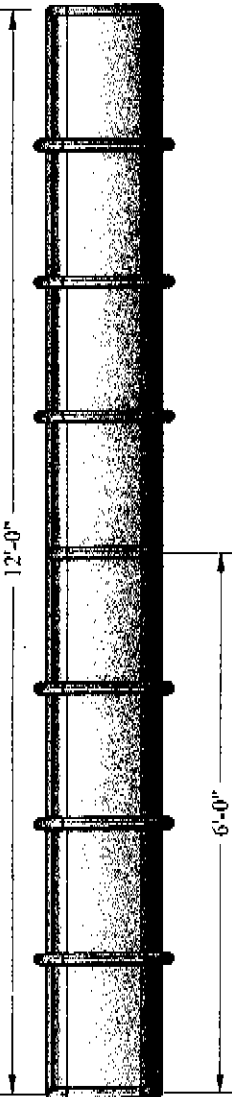

1
20
TOP VIEW
SCALE: 3/4"=1'

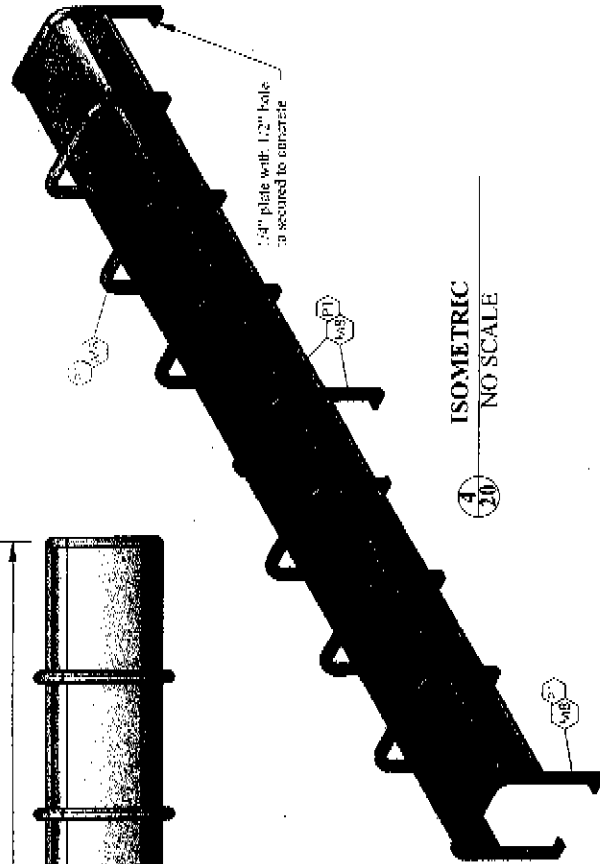

4
20
ISOMETRIC
NO SCALE

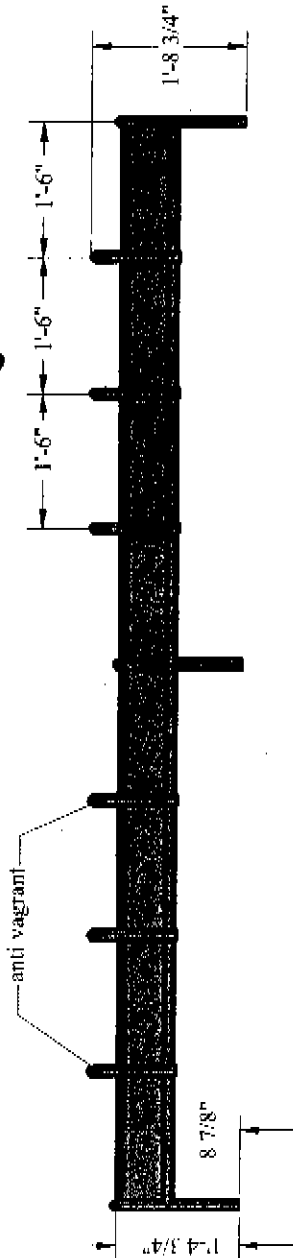

2
20
FRONT VIEW
SCALE: 3/4"=1'

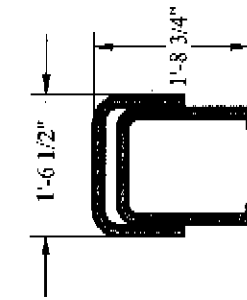

3
20
SIDE VIEW
SCALE: 3/4"=1'

12' Bench

Finish: Paint/Powder Coat

Blue/charcoal/Thermoblast

Materials / Substrate

- 1 2x4 LSI aluminum extrusion
- 2 1x2x1/8 aluminum rect tube
- 3 3/4" x 2" alum cap
- 4 2" alum pipe
- 5 2 1/2" alum pipe
- 6 6"x6"x3/8" Alum plate
- 7 Perforated Aluminum
- 8 1 1/2" alum pipe
- 9 2"x 1/4" sheet flat bar
- 10 1 1/2"x 1/4" alum angle
- 11 0.063" alum sheet

NOTE: The bench shall be Thermo Plastic Coated

PROJECT NAME: SONLINE	APPROVAL:	DATE:	DESCRIPTION:	SHEET:
ADDRESS: various	CLIENT:			20 OF 22
CITY/STATE: various	SALES:			
TELEPHONE: 878	DESIGN DATE: NOV 08 2008			
FAX NUMBER: 03	PROGRAMING:			
	SALES PERSON: Teresa Smith			
	ENGINEER:			
LDI CUSTOM MANUFACTURING				
<small> LDI, THE NAME OF THE BUSINESS, IS A REGISTERED TRADEMARK OF LDI INDUSTRIES, INC. IN THE UNITED STATES AND IN OTHER COUNTRIES. LDI INDUSTRIES, INC. IS NOT RESPONSIBLE FOR ANY REPRODUCTION OF THIS DRAWING OR FOR ANY DAMAGE TO PROPERTY OR PERSONS ARISING FROM THE USE OF THIS DRAWING. </small>				
<small> GENERAL NOTES: 1. ALL DIMENSIONS ARE UNLESS OTHERWISE SPECIFIED. 2. ALL MATERIALS SHALL BE AS SPECIFIED. 3. ALL MATERIALS SHALL BE NEW UNLESS OTHERWISE SPECIFIED. 4. ALL MATERIALS SHALL BE OF THE HIGHEST QUALITY AVAILABLE. 5. ALL MATERIALS SHALL BE OF THE HIGHEST QUALITY AVAILABLE. </small>				

20 Gal Trash Receptacle

Finish/Paint/Powder Coat

- (P1) Polyurethanes Powder-Coated Blue enameled T009-BL01

Materials / Substrate

- (M1) 2x4 Lx1 aluminum expansion
- (M2) 1x2x3/16 alum. rec. ribs
- (M3) 3/16" x 2" alum. cap
- (M4) 3" alum pipe
- (M5) 2 1/2" alum pipe
- (M6) 6"x6"x2/16" alum plate
- (M7) Recycled Aluminum
- (M8) 1 1/4" alum pipe
- (M9) 2"x 1/4" alum flat bar
- (M10) 1 1/2" x 1/4" alum angle
- (M11) 3/16x3" alum sheet

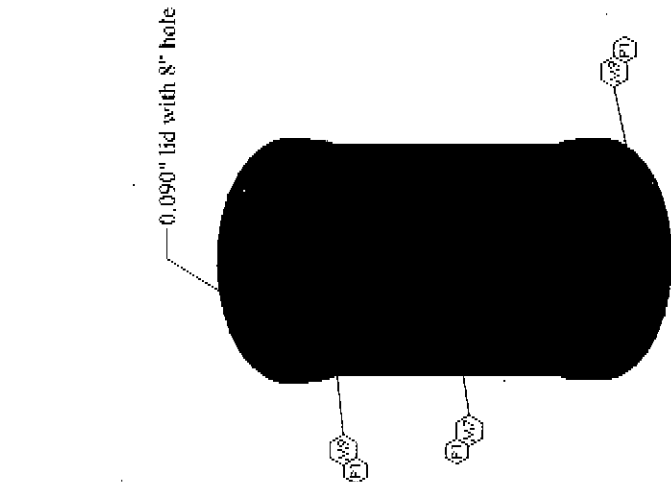

1 TOP VIEW
SCALE: 1 1/2"=1'

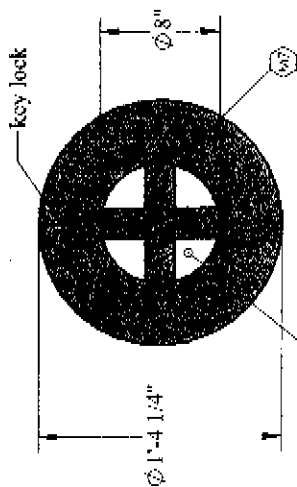

1 TOP VIEW
SCALE: 1 1/2"=1'

bottom open area for drainage

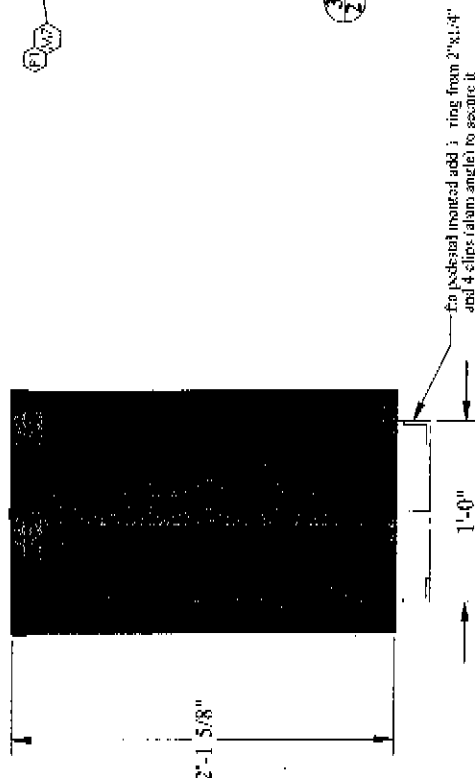

2 TOP VIEW
SCALE: 1 1/2"=1'

PROJECT NAME: S.W.OLIVE	DRAWINGS:	APPROVAL:	DATE:	DESCRIPTION:
ADDRESS: Various	SCALE: AS SHOWN	CLIENT:	BT	
CITY/STATE: Various	DRAWN BY: E. Infante	SALES:	BS	
TELEPHONE: NA	DESIGN DATE: Jan 04 '08	WORKLOAD:	RS	
FAX NUMBER: NA	SALES PERSON: Theresa Root	PROGRAMING:	RL	
		CHECK MANUFACTURING:	RS	



GENERAL NOTES
 1. ALL DIMENSIONS ARE TO FACE UNLESS OTHERWISE NOTED.
 2. MATERIALS TO BE USED SHALL BE AS SPECIFIED OR APPROVED EQUIVALENTS.
 3. FINISHES TO BE USED SHALL BE AS SPECIFIED OR APPROVED EQUIVALENTS.
 4. ALL MATERIALS SHALL BE NEW AND OF THE HIGHEST QUALITY AVAILABLE.
 5. THE CONTRACTOR SHALL BE RESPONSIBLE FOR OBTAINING ALL NECESSARY PERMITS.
 6. THE CONTRACTOR SHALL BE RESPONSIBLE FOR PROTECTING ALL EXISTING UTILITIES.
 7. THE CONTRACTOR SHALL BE RESPONSIBLE FOR PROTECTING ALL EXISTING SURROUNDINGS.
 8. THE CONTRACTOR SHALL BE RESPONSIBLE FOR THE PROTECTION OF ALL ADJACENT PROPERTIES.
 9. THE CONTRACTOR SHALL BE RESPONSIBLE FOR THE PROTECTION OF ALL ADJACENT UTILITIES.
 10. THE CONTRACTOR SHALL BE RESPONSIBLE FOR THE PROTECTION OF ALL ADJACENT LANDSCAPING.

Finish/Paint/Powder Coat
 Polyurethane Powder-coated
 Blue cadinal T099-BL01

Materials / Substrate

- (M1) 2x4 LNI aluminum extrusion
- (M2) 1x2x3/8 alum rest tube
- (M3) 3/16" x 2" alum esp
- (M4) 3" alum pipe
- (M5) 2 1/2" alum pipe
- (M6) 6"x6"x3/8" Alum plate
- (M7) Perforated Aluminum
- (M8) 1 1/4" alum pipe
- (M9) 2"x 1/4" alum flat bar
- (M10) 1 1/2"x 1/4" alum angle
- (M11) 0.063" alum sheet

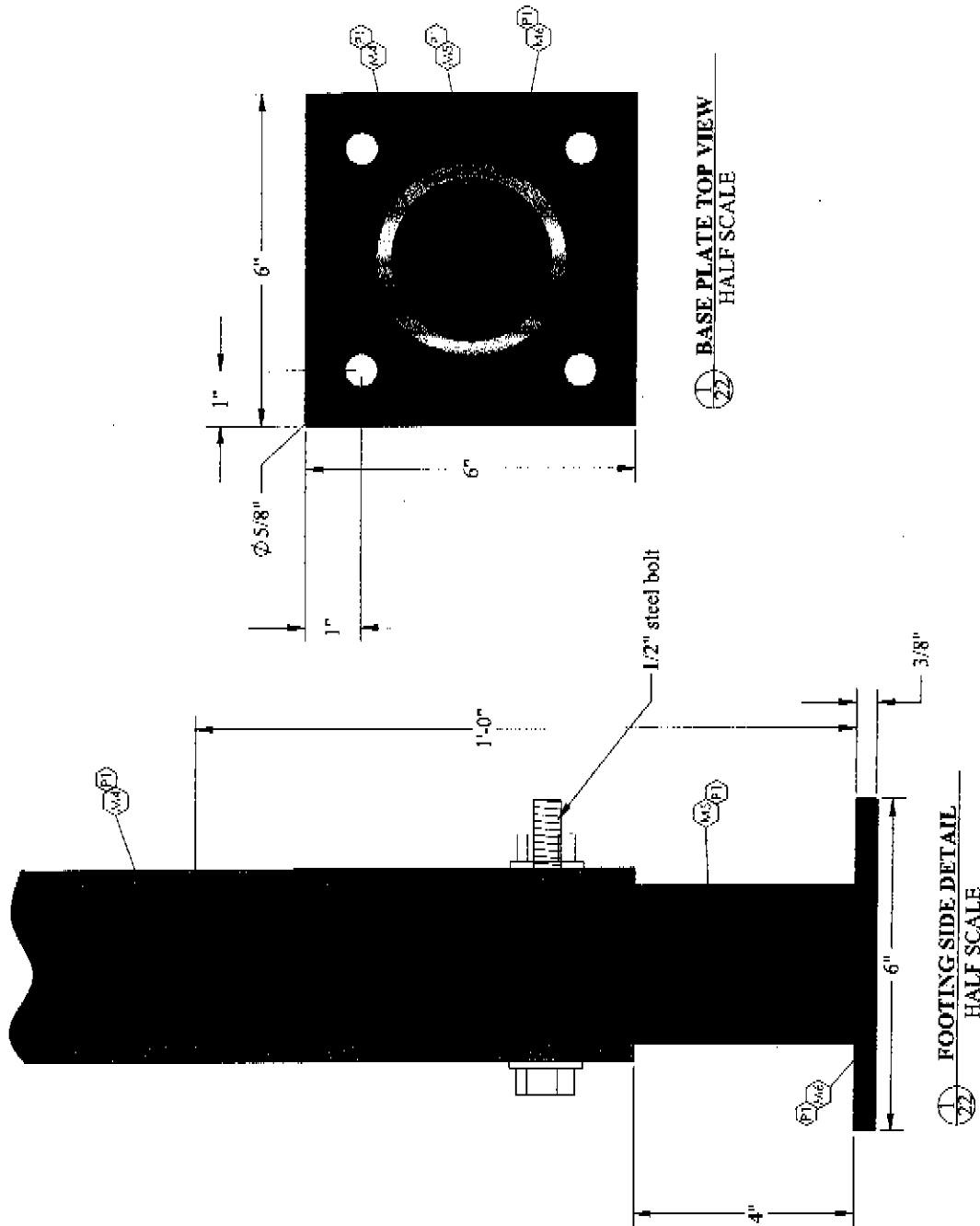

22 BASE PLATE TOP VIEW
 HALF SCALE

22 FOOTING SIDE DETAIL
 HALF SCALE

PROJECT NAME: SUZALINE	DRAWING:	DATE:	BY:	DESCRIPTION:
ADDRESS: Various	SCALE: AS SHOWN	RT	RS	
CITY/STATE: Various	DRAWN BY: F. Imbip	R3	R4	
TELEPHONE: 04	DESIGN DATE: NOV-04-2009	RS	RS	
FAX NUMBER: 04	SALES PERSON: Theresa Roth	RS	RS	
APPROVAL:		DATE:		
CLIENT:		BY:		
SALES:		DESCRIPTION:		
LAWYER:				
ENGINEER:				
DESIGNER:				
BUILDER:				
SIGNATURE:				



SHEET
 22 OF 22
 GENERAL NOTES
 1. ALL DIMENSIONS ARE APPROXIMATE UNLESS OTHERWISE SPECIFIED.
 2. ALL MATERIALS SHALL BE OF THE HIGHEST QUALITY AVAILABLE.
 3. ALL MATERIALS SHALL BE NEW UNLESS OTHERWISE SPECIFIED.
 4. ALL MATERIALS SHALL BE OF THE HIGHEST QUALITY AVAILABLE.
 5. ALL MATERIALS SHALL BE OF THE HIGHEST QUALITY AVAILABLE.