



City Council Staff Report

Date: July 6, 2016

CONSENT CALENDAR

Subject: APPROVAL OF PLANS, SPECIFICATIONS AND ESTIMATE (PS&E)
AND AUTHORIZATION TO BID THE PALM SPRINGS LIBRARY LED
INFORMATION SIGN, CITY PROJECT NO. 15-28

From: David H. Ready, City Manager

Initiated by: Engineering Services Department

SUMMARY

The construction documents (Plans, Specifications and Estimate) are completed and, in accordance with Section 7.03.040 of the Procurement and Contracting Code the City Council is required to approve and adopt plans, specifications and working details, and authorize the bid request for all public projects in excess of \$100,000. Approval of this project will allow staff to proceed with this public project, with an estimated cost of \$105,000.

RECOMMENDATION:

Approve the plans, specifications and estimate and authorize staff to advertise and solicit bids for the Palm Springs Library LED Information Sign, City Project No. 15-28.

STAFF ANALYSIS:

In 2014 the Library Board initiated a new capital project to install an electronic message display monument sign at the southeast corner of Sunrise Way and Baristo Road, as a means of communicating information to the public. The Library Board coordinated a preliminary monument sign design prepared by Best Signs, which is represented in Figures 1 and 2 on the next page.

ITEM NO. 26

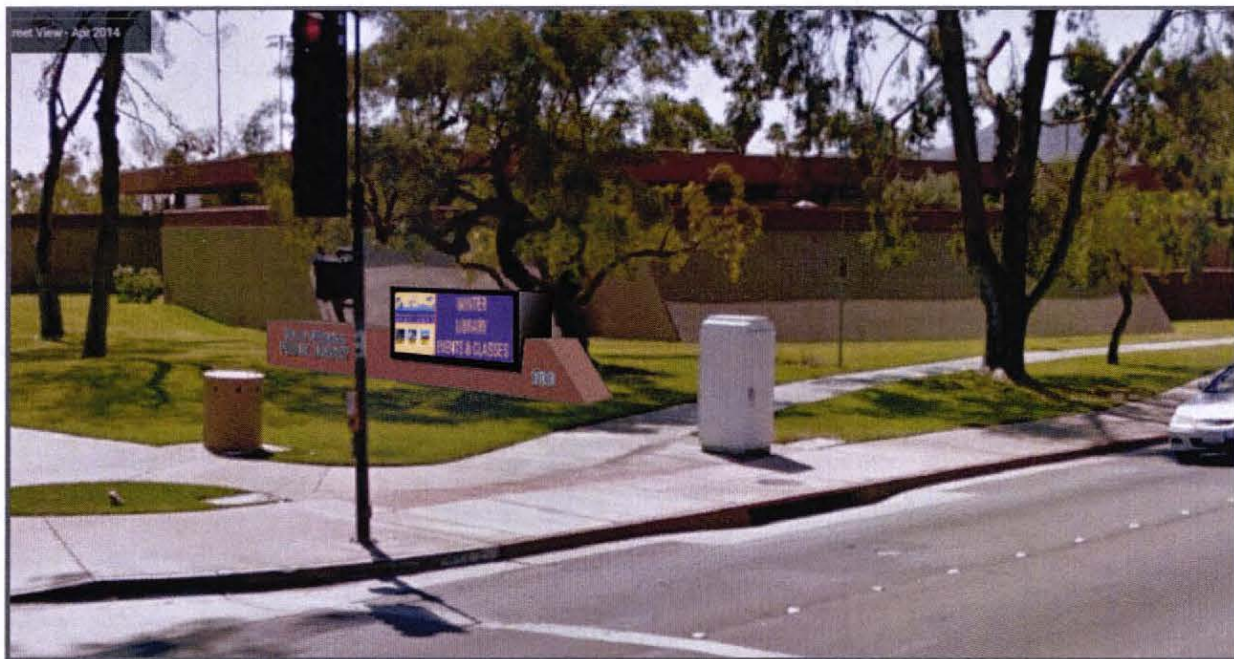

Figure 1

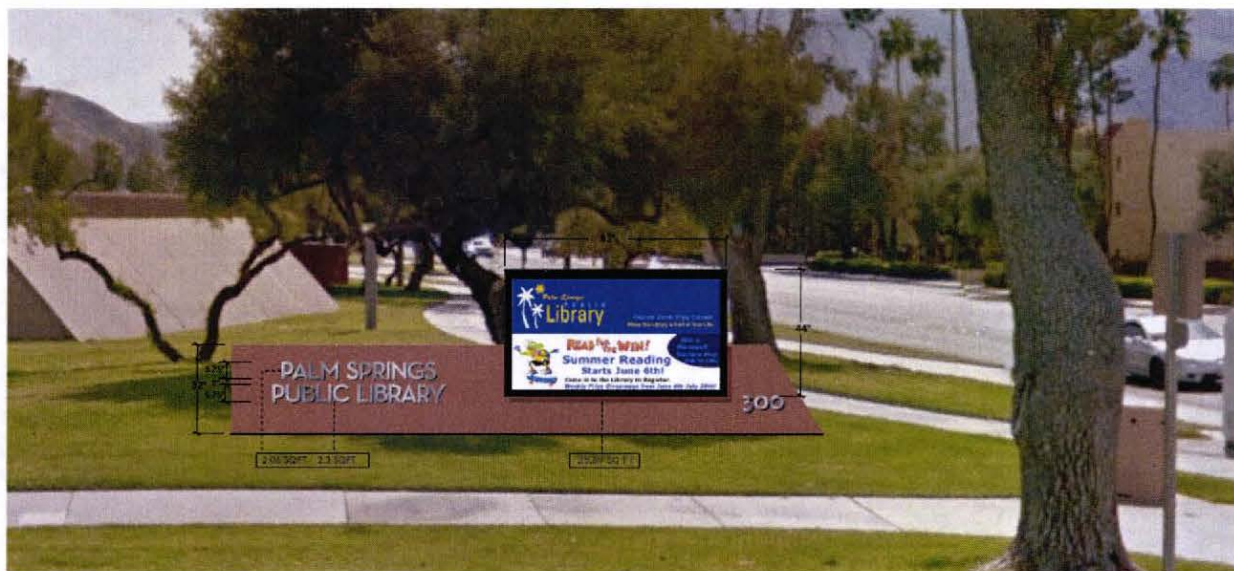

Figure 2

The installation of the proposed electronic message display monument sign is considered a public works capital project, and required preparation of appropriate designs and specifications for public bidding. The Library Board requested the City's Engineering Services Department undertake the necessary steps to deliver this project on behalf of the Library. Therefore, staff requested proposals from the City's various on-call landscape architectural firms to provide the necessary professional services to prepare contract documents for the project.

On October 21, 2015, the City Council approved an "On-Call" Landscape Architectural Services Agreement, (A6785), with David Evans and Associates, Inc. ("DEA"), to perform as-needed landscape architectural professional services for a variety of future City projects. On November 4, 2015, staff requested cost proposals from our on-call landscape architectural firms for the Palm Springs Library LED Information Sign, City Project No. 15-28, (the "Project"). Subsequently, on November 19, 2015, staff received a cost proposal from DEA in the amount of \$18,340 to prepare final design plans and specifications for the construction of an LED informational sign monument at the Palm Springs Library, located at 300 S. Sunrise Way.

The scope of work includes a cast-in-place concrete monument sign, electronic message center displays, minor turf removal, soil preparation, electrical system, lighting fixtures, rock cobbles, decomposed granite, decorative boulders, planting and irrigation, and all appurtenant on the southeast corner of S. Sunrise Way and E. Baristo Road. The location of the site of the proposed monument sign is shown in Figures 3 and 4.



Figure 3 – Site Location

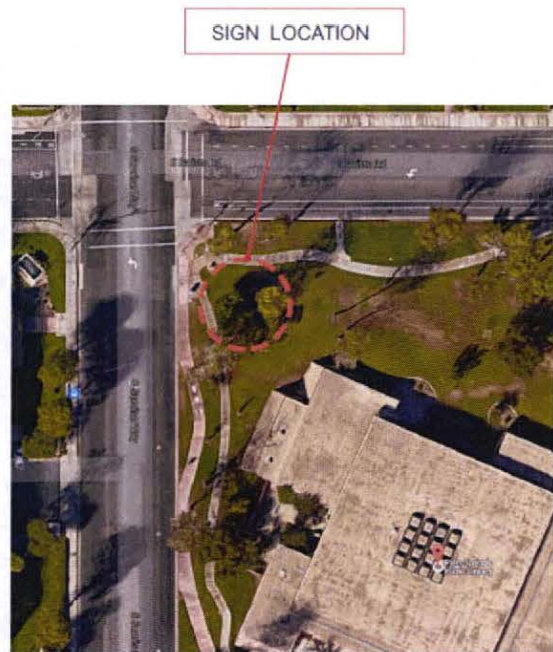

Figure 4 – Sign Location

The final monument sign design provides for a total of 29.11 square feet of sign area, consisting of 24.75 square feet of electronic message display, with "Palm Springs" and "Public Library" modern text lettering attached to the sign structure representing another 4.36 square feet. Construction details for the monument sign are provided in Figures 5 and 6.

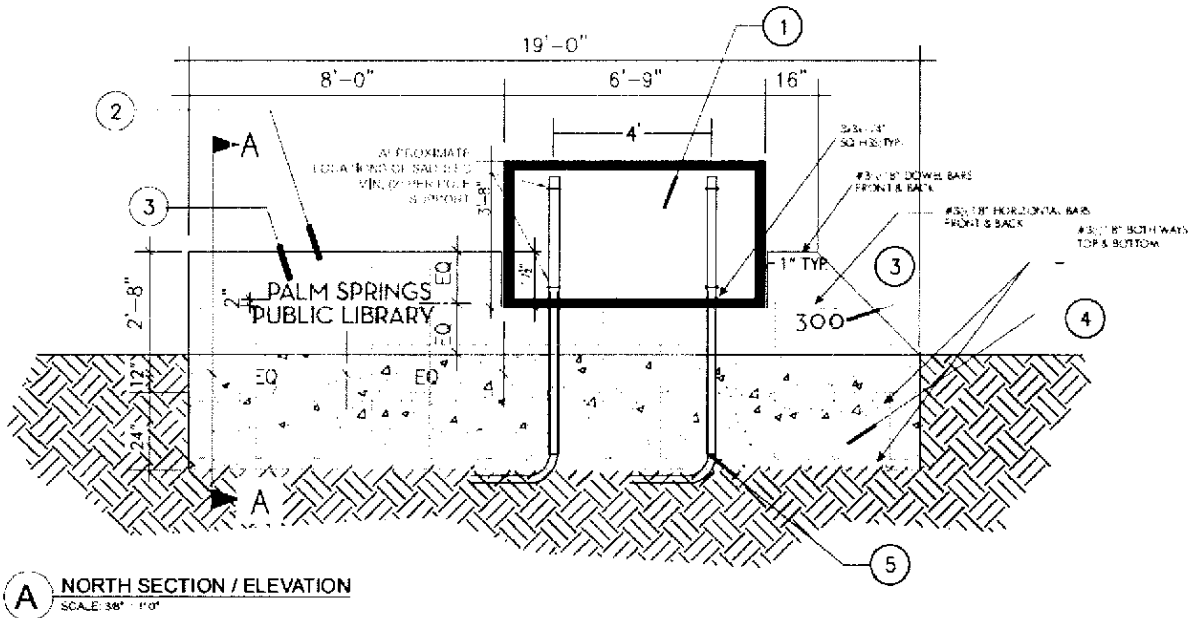

Figure 5 – Sign Detail

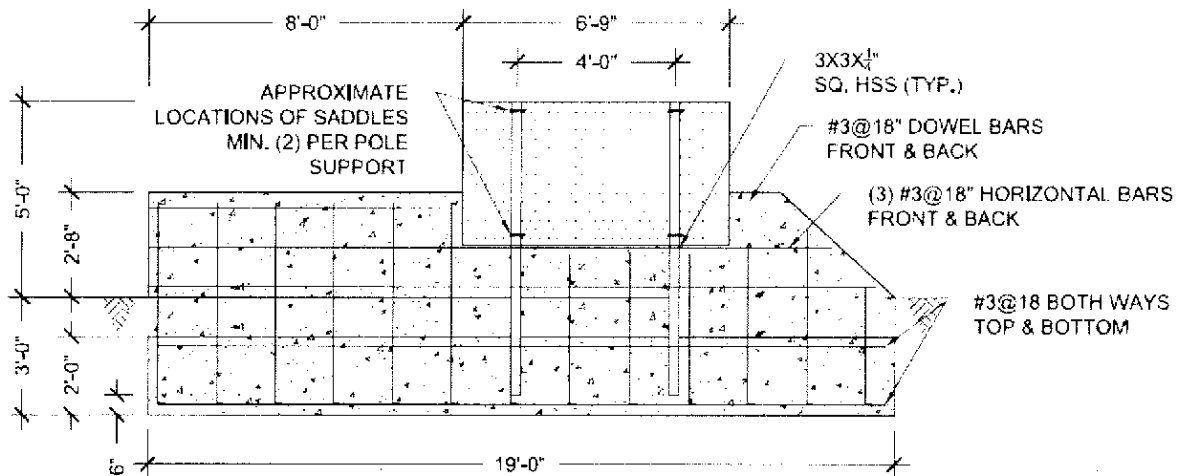

Figure 6 – Sign Detail

The construction documents prepared by DEA have been reviewed and approved by the City's Building Department. The proposed monument sign has also been reviewed by the City's Planning Services Department under its Sign Permit/Sign Program Review procedures, and the Planning Services Department has determined the architectural changes to the Library building are appropriate and have issued approval through Case No. 15.103.

The project includes removal of existing turf and landscaping and installation of new desert landscaping, including golden barrel cactus, outback sunrise emu, cedros island verben, and new gold lantana, and hardscaping (decomposed granite and Arizona cobble) as generally shown in Figure 7.

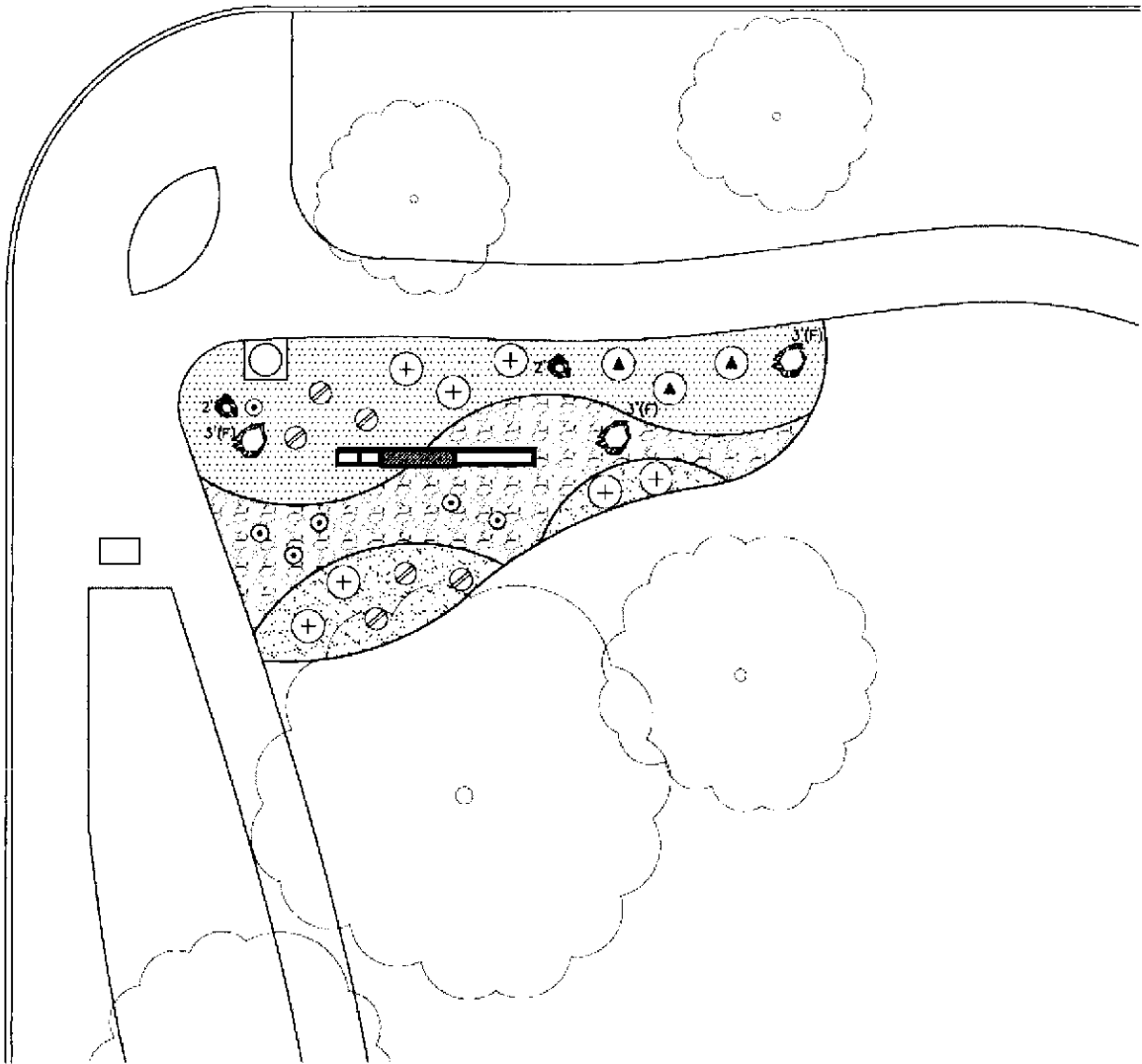

Figure 7 – Landscaping Detail

On June 23, 2016, the Library Board reviewed and approved the monument sign details, and recommended that the City proceed with formal bidding of the project. The contract documents are on file with the Public Works and Engineering Department. Staff recommends that the City Council approve the contract documents and authorize staff to formally solicit construction bids for the Project.

With City Council approval, staff will advertise the project in the *Desert Sun*, submit the Notice Inviting Bids to plan rooms, and provide the bid documents available free of charge to prospective bidders. A copy of the contract documents are on file with the Public Works & Engineering Department. The following **tentative** schedule has been identified for the bid process:

Notice Inviting Bids to be posted:
Deadline for receipt of bids:
Contract awarded by City Council:

July 7, 2016
3:00 PM, August 11, 2016
September 7, 2016

ENVIRONMENTAL IMPACT:

Section 21084 of the California Public Resources Code requires Guidelines for Implementation of the California Environmental Quality Act ("CEQA"). The Guidelines are required to include a list of classes of projects which have been determined not to have a significant effect on the environment and which are exempt from the provisions of CEQA. In response to that mandate, the Secretary for Resources identified classes of projects that do not have a significant effect on the environment, and are declared to be categorically exempt from the requirement for the preparation of environmental documents. In accordance with Section 15301 "Existing Facilities," Class 1 projects consist of the operation, repair, maintenance, permitting, leasing, licensing, or minor alteration of existing public structures; therefore, the Palm Springs Library LED Information Sign, City Project. No. 15-28 is considered categorically exempt from CEQA, and a Notice of Exemption has been prepared and filed with the Riverside County Clerk. A copy of the Notice of Exemption is included as **Attachment 1**.

FISCAL IMPACT:

A total of \$70,000 was previously budgeted for the Project through the Library Endowment Trust Fund (Fund 151). The final construction estimate for the Project is \$105,000. Staff is recommending that the City proceed with bidding this project to obtain firm construction bids; following bidding, staff will report the bid results to the Library Board and obtain direction on their recommendation to proceed to the City Council for award, with an appropriation of additional funding at that time from the Library Endowment Trust Fund. This project will be 100% funded through the Library Endowment Trust Fund.

SUBMITTED:

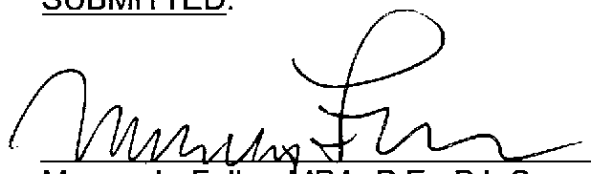

Marcus L. Fuller, MPA, P.E., P.L.S.
Assistant City Manager/City Engineer

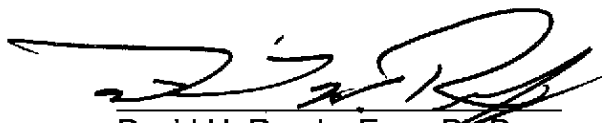

David H. Ready, Esq., Ph.D
City Manager

Attachments:

1. CEQA Notice of Exemption

Attachment 1

NOTICE OF EXEMPTION

To: Office of Planning and Research
1400 Tenth Street, Room 121
Sacramento, CA 95814

From: City of Palm Springs
3200 E. Tahquitz Canyon Way
Palm Springs, CA 92262

Clerk of the Board
County of Riverside
P.O. Box 751
Riverside, CA 92502-0751

Project Title: Palm Springs Library LED Information Sign, City Project No. 15-28

Project Applicant: City of Palm Springs

Project Location (Specific): Palm Springs Library, located at 300 S. Sunrise Way

Project Location (City): City of Palm Springs

Project Location (County): Riverside

Project Description: The scope of work includes the construction of an LED display informational monument sign including foundation. The scope of work shall consist of minor turf removal, soil preparation, electrical system, lighting fixtures, installation of rock cobbles, installation of decomposed granite, decorative boulder placements, landscape planting and irrigation, 90-day landscape maintenance and all appurtenant work.

Name of Public Agency Approving Project: City of Palm Springs

Name of Person or Agency Carrying Our Project: City of Palm Springs, Public Works & Engineering Department
3200 E. Tahquitz Canyon Way, Palm Springs, CA 92262

Exempt Status: (check one)

- Ministerial (Sec. 21080(b) (1); 15268);
- Declared Emergency (Sec. 21080(b) (3); 15269(a));
- Emergency Project (Sec. 21080(b) (4); 15269 (b)(c));
- Categorical Exemption. State type and section number: 15301 Class 1 (a) – Existing Facilities
- Statutory Exemptions. State code number:

Reasons why project is exempt: Class 1 consists of the operation, repair, maintenance, permitting, leasing, licensing, or minor alteration of existing public structures, facilities, mechanical equipment or topographical features involving negligible or no expansion of use beyond that existing at the time of the lead agency's determination. Interior or exterior alterations involving such things as interior partitions, plumbing, and electrical conveyances, therefore, the Palm Springs Library LED Information Sign, City Project No. 15-28, is considered categorically exempt from CEQA.

Lead Agency Contact Person: Marcus L. Fuller Area Code/Telephone/Extension: (760) 322-8380

If filed by applicant:

1. Attach certified document of exemption finding.
2. Has a Notice of Exemption been filed by the public agency approving the project? Yes No

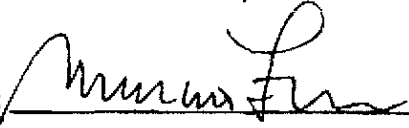
Signature:  Date: 6/22/16

Title: Assistant City Manager/City Engineer

Signed by Lead Agency Signed by Applicant

Authority cited: Sections 21083 and 21110, Public Resources Code
Reference: Sections 21108, 21152, and 21152.1, Public Resources Code.

Date received for filing at OPR: _____