



City Council Staff Report

Date: October 5, 2016 CONSENT CALENDAR

Subject: Approve a purchase with Outdoor Creations for Replacement Benches for Downtown, Uptown and Indian Canyon.

From: David H. Ready, City Manager

Initiated by: Maintenance & Facilities Department

SUMMARY

The City Council will consider the purchase of new concrete benches to replace existing damaged and no longer serviceable benches in the Downtown, Uptown, and Indian Canyon exterior locations.

RECOMMENDATION:

- 1) Award the purchase of new concrete benches as specified in Invitation for Bid #16-07-A to Outdoor Creations Inc. of Anderson, California in the amount of \$55,175.80, which includes applicable CA sales tax and delivery fee.
- 2) Authorize City Manager to execute all necessary documents.

STAFF ANALYSIS:

The City currently owns and maintains a total of 68 concrete benches on the City street and pedestrian areas, located throughout its Downtown, Uptown, and Indian Canyon Districts. Of these 68 concrete benches 39 of them have back supports provided and 29 are non-backed benches. These concrete benches are approximately 20 years old and were purchased as color coated concrete. Past practice was to paint all benches as needed, however over time, much of the primer and paint applied is no longer adhering due to age and repeated applications.

Numerous repairs, patches and reapplication of the paint by sanding, priming and resealing have caused the benches to deteriorate and need to be replaced.

Replacement of all these painted benches will greatly improve the aesthetics of the Downtown, Uptown and Indian Canyon districts areas in which they are located. All new benches will have a 4 inch seat delineation as a seat separator located in the center of the seating area making them less desirable for laying on and more comfortable for

multiple people to sit on at once, as shown in **Attachment 1**. The benches will be in keeping with the same bench color it has established throughout the downtown area which is called Terra Cotta and will have a satin finish and be graffiti coated.

The Procurement and Contracting Division worked closely with Maintenance and Facilities Staff to develop the specifications and conducted Invitations for Bid (IFB) #16-07-A for the acquisition. The bid notice was distributed and five bids were received:

Vendor	Bid Price*
Outdoor Creations	\$55,175.80
Universal Precast Concrete	\$55,366.55
Great Western Park and Playground	\$99,124.60
NR Development Inc.	\$103,500.00
Peterson Manufacturing	\$104,633.40

*Inclusive of delivery and required CA sales tax.

Outdoor Creations was the lowest responsive responsible bidder to meet all specifications and as such Staff is recommending award to them.

FISCAL IMPACT:

Funds have been allocated in the budget and are available in account number 001-4210-43061 – Downtown - Downtown Maintenance.

SUBMITTED:

Prepared by:

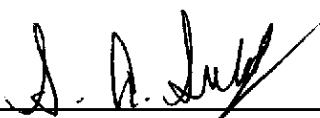

Staci A. Schafer,
Director of Maintenance & Facilities

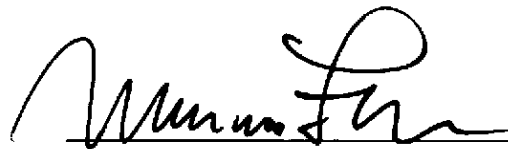

Marcus L. Fuller,
Asst. City Manager/City Engineer

Approved by:

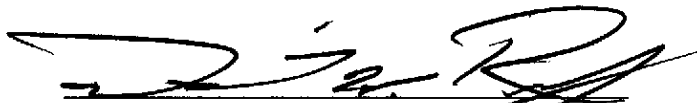

David H. Ready, City Manager

1. Bench Specifications and Renderings

ATTACHMENT "1"

BACKED BENCH

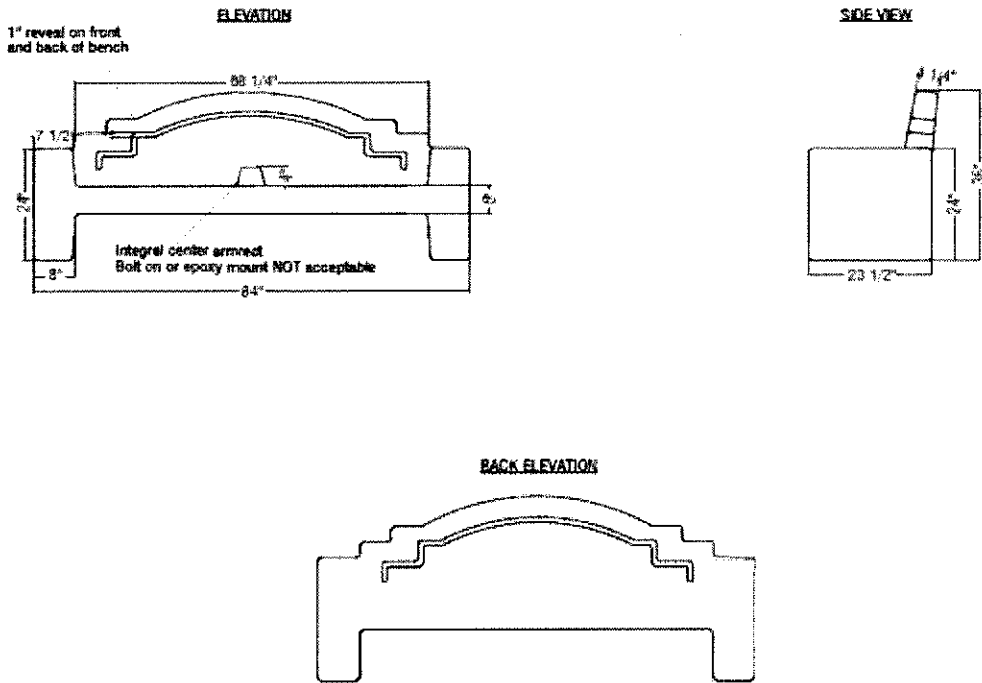

NON-BACKED BENCH

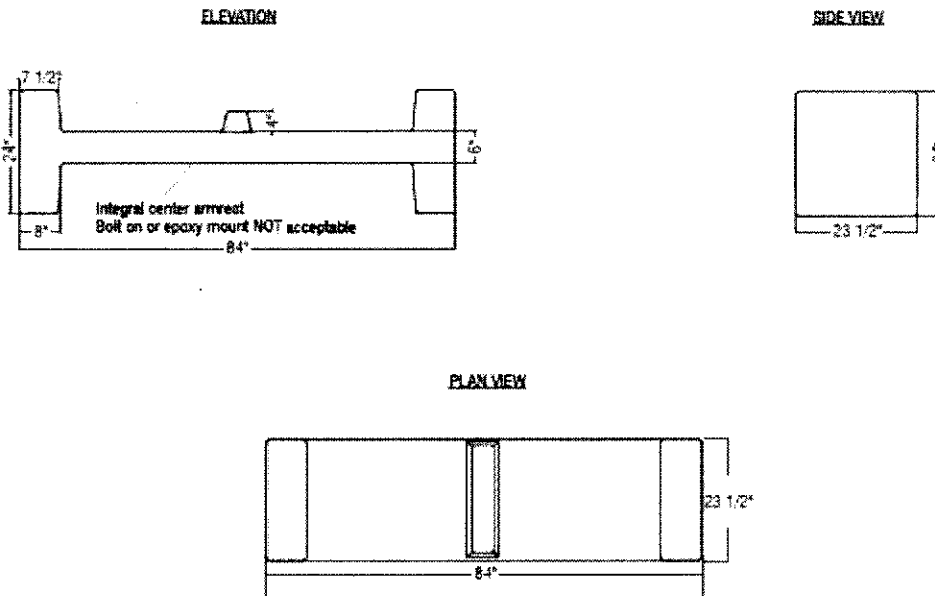

Existing damaged benches
to be replaced

