

NO.	REVISIONS	APPROVED	DATE

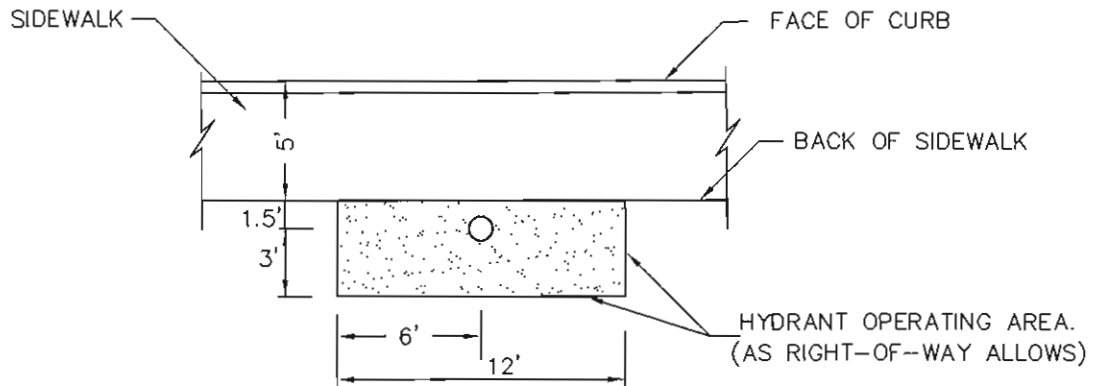

CONDITION NO. 1 HYDRANT LOCATION - 5' SIDEWALK

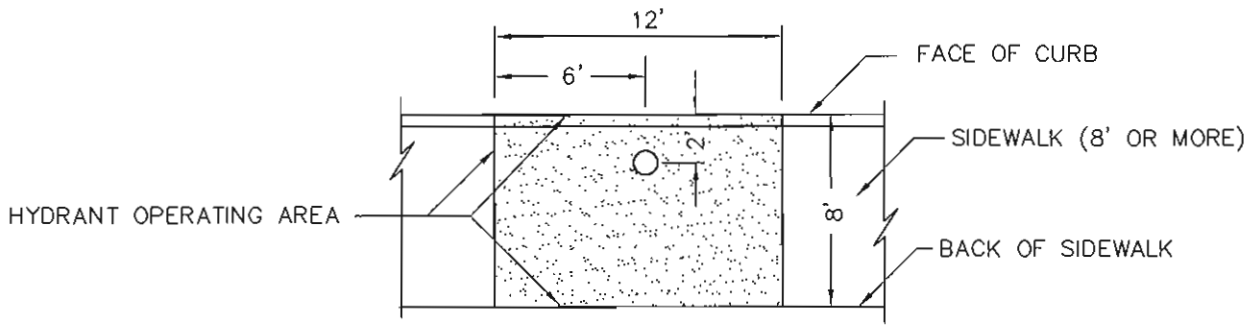

CONDITION NO. 2 HYDRANT LOCATION - 8' SIDEWALK OR MORE

GENERAL NOTES:

1. PROJECT ENGINEER SHALL STAKE HIDRANT LOCATIONS AS NOTED BY STATIONING ON THE IMPROVEMENT PLANS.
2. IF HYDRANT IS IN MOUNDED AREA, A RETAINING WALL SHALL BE BUILT AROUND IT.
3. A MINIMUM OF 48" CLEARANCE (PER A.D.A. REQUIREMENTS) IS REQUIRED AROUND HYDRANTS LOCATED WITHIN SIDEWALKS.
4. HYDRANT OPERATING AREAS SHALL BE KEPT FREE OF OBSTRUCTIONS, INCLUDING TREES AND PLANTS.

<p align="center">CITY OF PALM SPRINGS PUBLIC WORKS & ENGINEERING DEPARTMENT</p>	<p>APPROVED: <i>[Signature]</i></p>	<p>DATE: <i>12/10/07</i> 28931</p>
	<p>CITY ENGINEER</p>	<p>R.C.E.</p>
<p align="center">FIRE HYDRANT LOCATION</p>	<p>DRAWN BY: G.F.F.</p>	<p>FILE NO. STANDARDS</p>
	<p>CHECKED BY: M.L.F.</p>	<p>DWG. NO. 901</p>